

Burroughs Instruction Book

on

Class 3 Machines

BOOK NO. 3B

PROPERTY OF AND TO BE RETURNED TO
BURROUGHS ADDING MACHINE COMPANY
DETROIT, MICHIGAN

INTRODUCTION

The purpose of this book is to assist the student in the study of the construction and adjustment of the Class 3 Burroughs Adding Machine.

While this model differs somewhat in appearance from the Class 1 machine it retains the original Burroughs principles of construction.

The student's knowledge of the Class 1 machine will enable him to make rapid progress if he compares the resulting action of the parts and sections in the Class 3 machine to the corresponding parts and actions in the Class 1 machine.

7000 SECTION

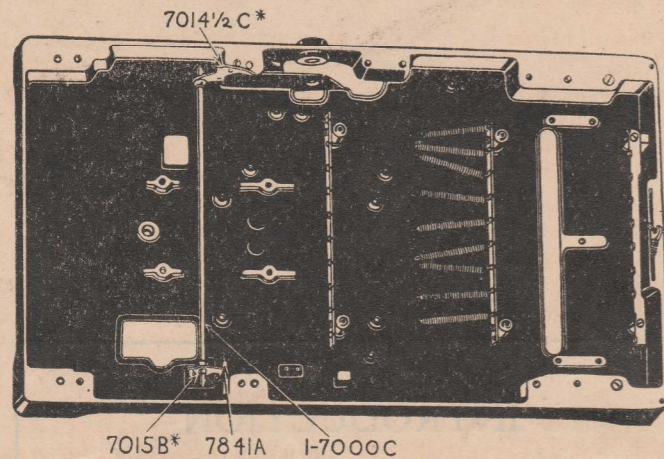

7200 SECTION

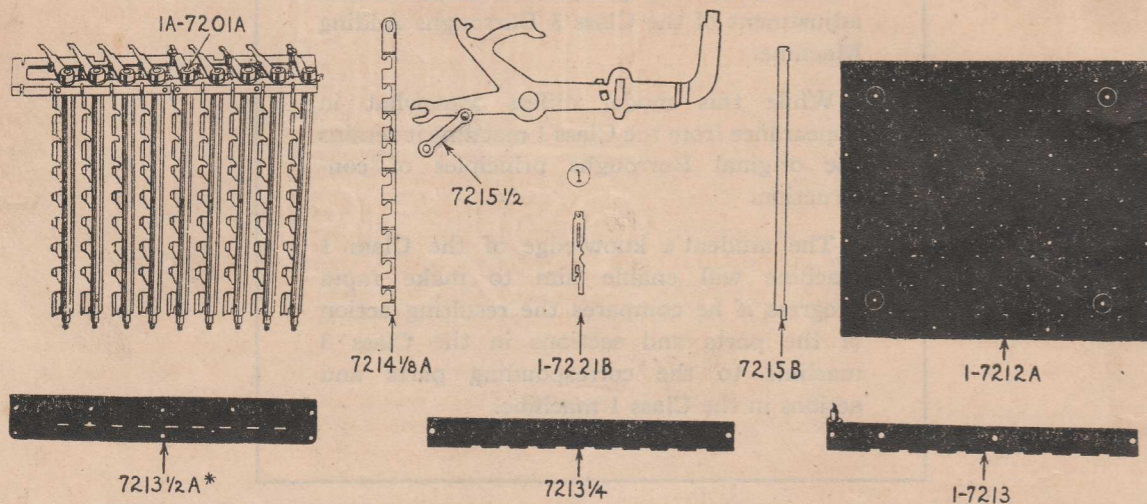

7300 SECTION

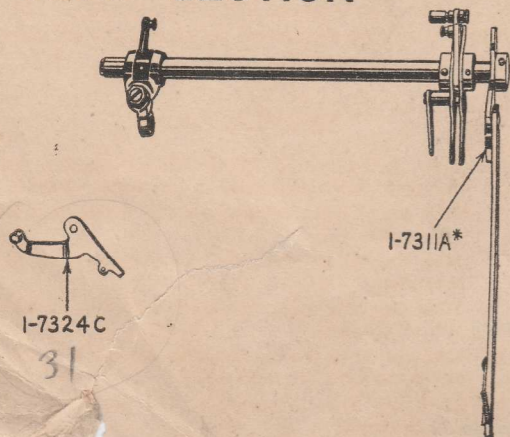

7600 SECTION

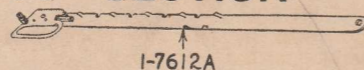

7800 SECTION

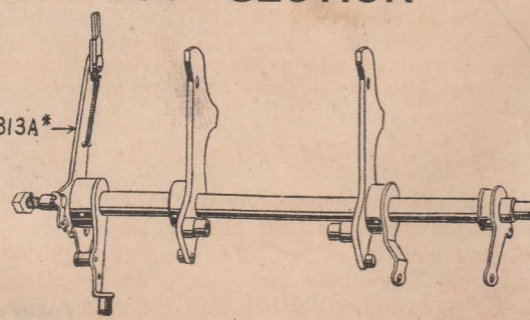

SECTIONS

Interlock 7000 Section

The purpose of the interlock 1-7000C is to compel full depression of the total and sub-total keys. This safeguard is necessary in order to separate the totaling and listing mechanisms.

The space lock blocks the interlock and compels the taking of a spacing stroke so that when a carry takes place the carry pawls can be restored to a normal position. During the entire operation of the machine the interlock prevents the depression of the total and sub-total keys.

The part 7015B (on 1-7000C) is connected to the total key by the link 7215 1/2. Unless the total key or sub-total keys are fully depressed, the part 7014 1/2 C (on 1-7000C) raises the 1-7324C which locks the 1-7311A and prevents the machine from being operated.

The total keys are held depressed during the operation of the machine by the roll 7841A (on 7015B) which engages the cam surface shaft on the lower part of 1-7813A.

Adjustments

The 1-7324C should have good hold on the 1-7311A when the space lock unit blocks the operation of the interlock. The 1-7324C must clear the 1-7311A during the operation of the machine.

SELF-QUESTIONS

- 1—How does the interlock compel a full depression of the total and sub-total keys?
- 2—How does the interlock prevent depression of the total and sub-total keys after the handle has been started?
- 3—How does the space lock block the interlock after an amount has been listed?
- 4—Why should the part 1-7324C have clearance over the 1-7311A when the total or sub-total levers are fully depressed?
- 5—What would the printed total show if the total lever could be depressed without taking a spacing stroke with the carry pawl in a carry position?

7200 Section

With the operating lever in normal position the keyboard is flexible, that is, any key can be depressed in any column, even though one key may have been previously depressed in the same column. When the operating lever

is started all keys are locked against depression. The key stems when depressed are the index bars which limit the adding sector.

Keystems 1-7221B

The cams on the keystem 1-7221B when the key is depressed moves the 1A-7201A and allows it to seat in the notch above the cam holding the keystem in depressed position.

As the 1A-7201A is moved by the cam on a keystem, a key previously depressed in that column will restore to normal.

The lower end of the keystem 1-7221B when depressed extends below the bottom of the keyboard plates far enough to engage the projections of the 1-7612A.

The keystem 1-7221B also has a small opening at its lower end, which is engaged by the locking strip 7214 1/8 A when the operating handle is started forward.

Adjustments

The keystem 1-7221B should move freely so that it will restore quickly when released.

To remove a keystem, remove keyboard section, take off front 7213 1/2 A and rear 1-7213 keyboard plates, also the plate 7213 1/4 immediately in front of the keystem that is to be removed. Depress the entire vertical column of keys to take all tension off the retaining strip 7215B, withdraw the strip 7215B following up with another strip, until it has passed the keystem which is to be removed, leaving a gap between the two strips so the keystem can be removed.

Note: The bottom keyboard plate (1-7212A) should not be removed as this part retains all keystems in position.

SELF-QUESTIONS

- 6—How does a key (1-7221B) when depressed release one previously depressed in the same column?
- 7—How are all keys locked when the machine is being operated?
- 8—How are the keys released by the operation of the machine?
- 9—How are the keys released with the total and sub-total keys?
- 10—Can the keys remain depressed when the total or sub-total keys are held down?
- 11—How are keys released by the separate column release keys?

7000 SECTION

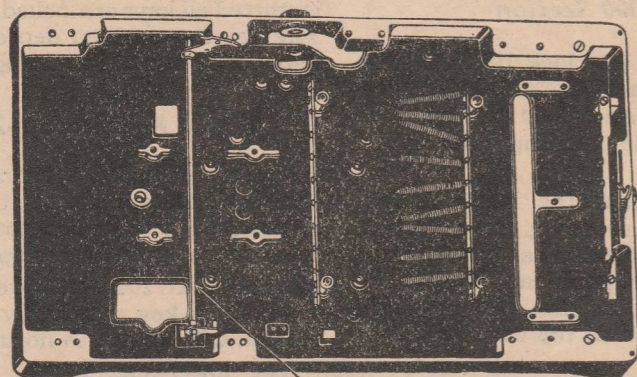

1-7000C

7200 SECTION

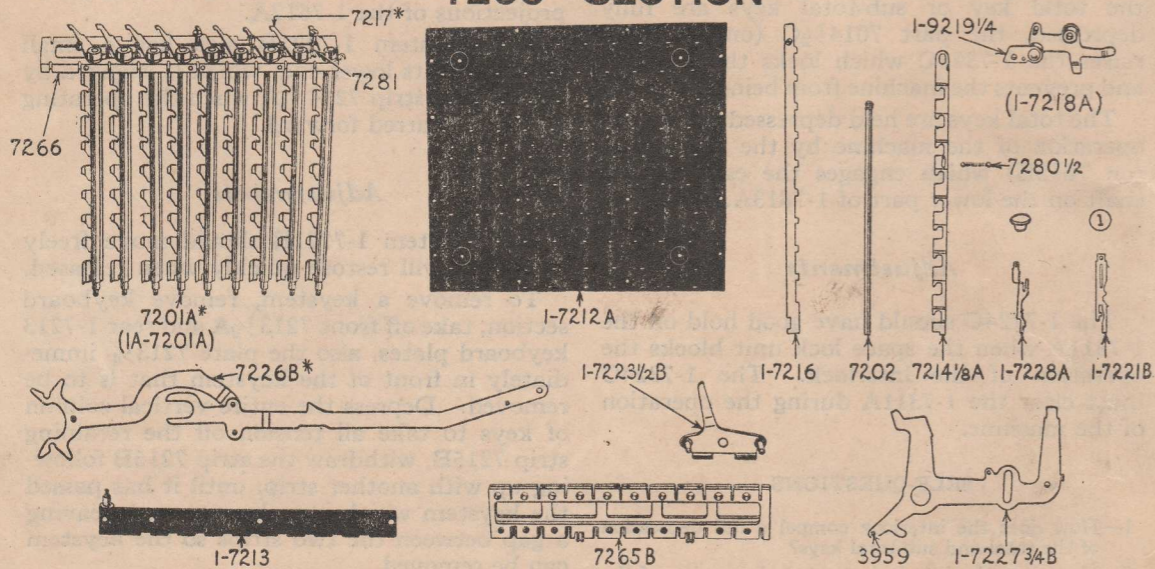

7600 AND 7700 SECTIONS

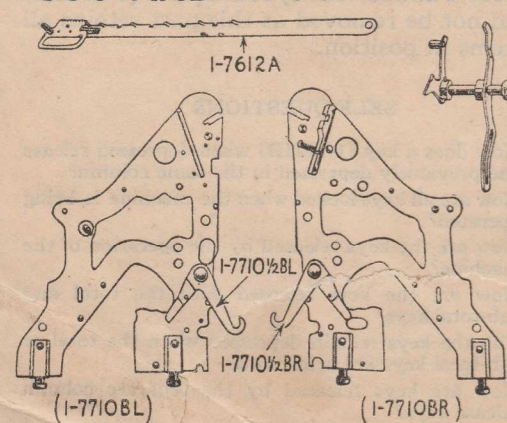

7800 SECTION

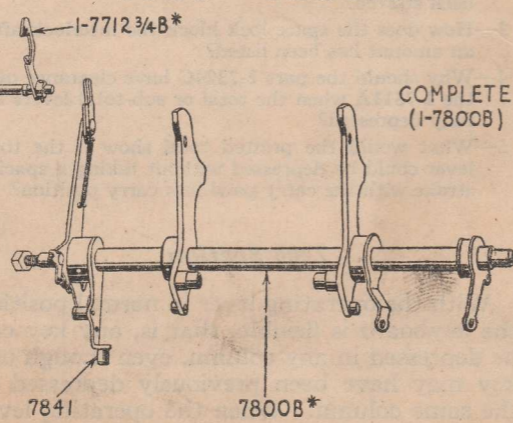

Locking Bail 1A-7201A

This bail swings in the 7265B and the 7266. It engages each keystem in the entire column. Keys are released by its downward movement which is secured in four different ways, viz.: Depression of keystems 1-7221B, and separate column release key 1-7228A, the depression of the total and sub-total keys and the operation of the key restoring unit 1-7218A.

The restoring levers 7217 are pinned to the shaft 1A-7201A. The spring 7281 holds the bail against the strip 1-7216, or the keystems when depressed.

Adjustments

The locking bail 1A-7201A should move freely and have a good hold on all keystems.

To remove one of these bails, take off the 7217 which is pinned to the shaft 7201A (1A-7201A). Remove the front casting 7265B and then the bail can be easily taken out.

SELF-QUESTIONS

- 12—What other purpose have the levers 7217 in addition to releasing all keys?
- 13—What limits the locking bail 1A-7201A when the keys are depressed?
- 14—What limits the locking bail when no keys are depressed?
- 15—When the locking bail 1A-7201A is held out of normal position and the machine operated, why does the No. 9 type print?

Key Restoring Unit 1-7218A

The key restoring unit 1-7218A swings on the 1-7213 and operates the 1A-7201A through the strip 1-7216 which has projections that engage the 7217 levers. This unit is operated by the part to which the 7841 is attached.

Adjustments

The flipper pawl 1-9219 1/4 should move freely. With the sub-total key depressed it should clear the 7841 roll (on 1-7800B).

The total and sub-total keys when depressed should release all keystems 1-7221B even when locked against complete depression by the interlock-1-7000C.

When the total and sub-total keys are fully depressed there should be 1/32" clearance in the

upper part of the slots of the total and sub-total lever so as to prevent binding of the 7217 and 1-7612A during a machine operation.

SELF-QUESTIONS

- 16—What limits the key restoring unit 1-7218A when the machine is in normal position?
- 17—How does the 1-7218A release the key?
- 18—How is the 1-7218A operated by the mechanism of the machine?
- 19—How is the 1-7218A operated by the total and sub-total keys?

Locking Strips 7214 1/8 A

The locking strips 7214 1/8 A move in guide slots of the 7266 and the 7265B. The springs (7280 1/2) are connected with the locking strips and to the projections on the bottom keyboard plate (1-7212A) which moves the locking strip into a locking position when the shaft 7202 is released by the hook 1-7710 1/2 BR and BL (on 1-7710 BR and BL).

SELF-QUESTIONS

- 20—How do the locking strips (7214 1/8 A) lock the keys when the operation of the machine begins?
- 21—What parts operate the locking strips and how are those parts controlled?

Sub-total Key 1-7227 3/4 B

The sub-total key swings on the 7800B shaft; when depressed it also depresses the total key to operate the interlock 1-7000C, raise the arm 7226B and lock the non-add key.

The rear upper arm is higher than the corresponding arm of the total lever to change the position of the character index.

The rear lower arm acts as a guide and carries a stud 3959 which locks the sub-total key when the total key is depressed, and prevents the return of the sub-total key during the operation of the machine.

SELF-QUESTIONS

- 22—Why does the sub-total key when depressed lower the total key?
- 23—Why is the upper part which moves the character index 1-7712 3/4 B higher than the same part of the total key?
- 24—What is the purpose of the lower stud (3959) and prong?
- 25—When the sub-total key is depressed why does the 7226B remain in a neutral position between the studs in the 1-7223 1/2 B in the earlier constructed machines?

7000 SECTION

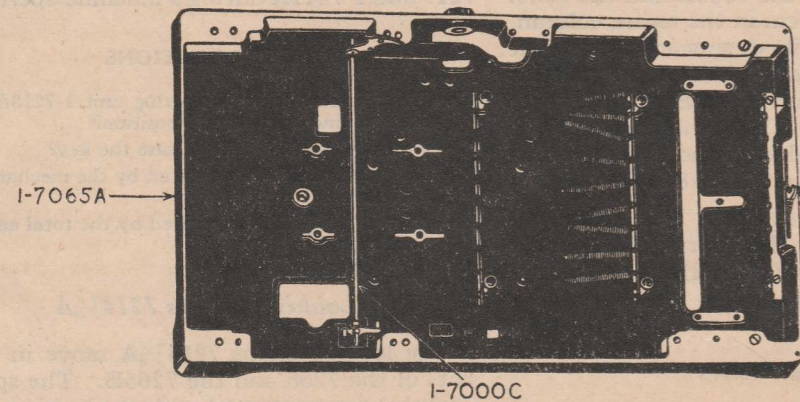

7200 SECTION

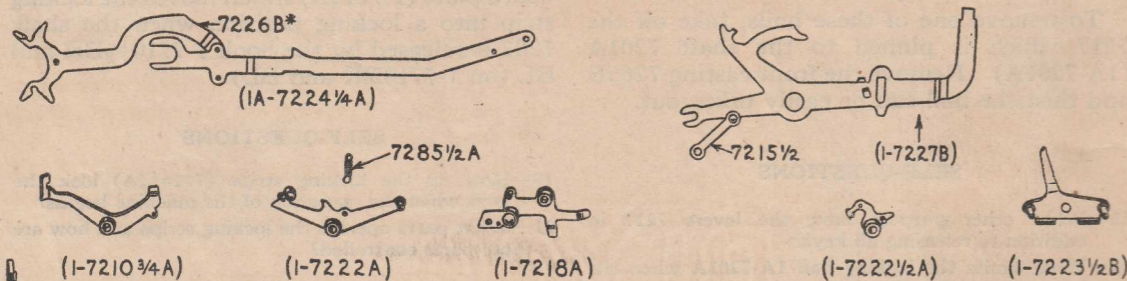

7300 SECTION

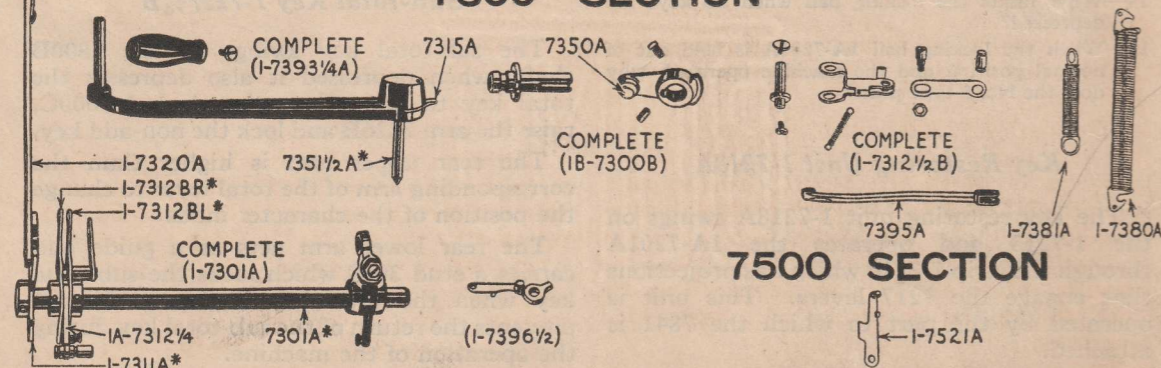

7600 SECTION 7700 SECTION

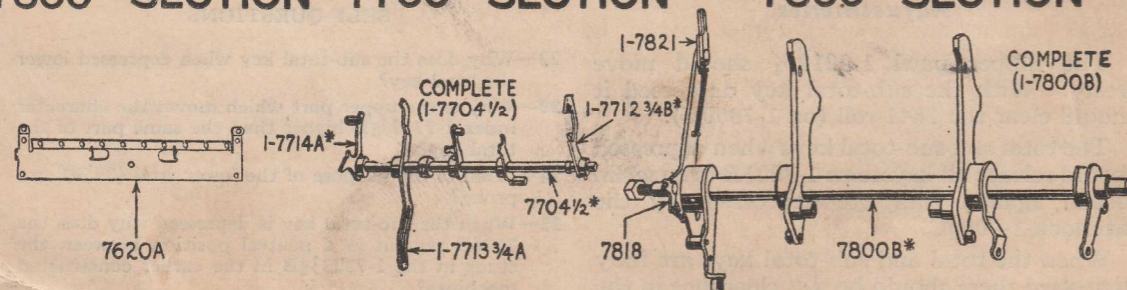

7500 SECTION

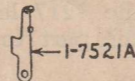

7800 SECTION

Total Key 1-7227B

The total key swings on the 7800B shaft (of 1-7800B). When depressed it operates the following:

Key release unit 1-7218A.
Interlock 1-7000C.
Character index 1-7712³/₄B (of 1-7704¹/₂).
Arm 7226B (of 1A-7224¹/₄A).
Ribbon shift arm 1-7521A.

The rear upper arm locks the non-add key against depression.

The front upper arm moves 1-7704¹/₂.
The link 7215¹/₂ moves the 1-7000C.
The fork raises the 7226B.

SELF-QUESTIONS

- 26—How does the total key operate the key release unit?
27—How does the total key operate the interlock 1-7000C?
28—How does the total key operate the character index 1-7712³/₄B?
29—How does the total key operate the shift arm 1-7521A?
30—How does the total key lock the non-add mechanism?
31—How does the total key prevent the disengagement of the adding wheels and the adding racks on the forward stroke?

The Non-add Mechanism

The non-add mechanism which is depressed by the non-add key is operated through the following parts:

The part 1-7222A which is pivoted to the left side frame, lifts the part 1-7210³/₄A into position to disable the 1-7821. It also cams the arm 1-7714A (on 1-7704¹/₂) which locates the non-add character type, and when depressed is released by the 1-7222¹/₂A when the total or sub-total levers are depressed, or by the 7818 on return stroke of a non-added operation.

The part 1-7713³/₄A (on 1-7704¹/₂) acts as an interlock for the non-add key to prevent its depression or release when the operation of the machine is started. The 1-7713³/₄A swings on the shaft 7704¹/₂ and is operated by the 7800 section.

SELF-QUESTIONS

- 32—How is an amount printed and not added?
33—What are the functions of the part 1-7222A?
34—How is the part 1-7222A locked when the machine is being operated?

- 35—How is the 1-7222A locked when the total keys are depressed?
36—If the 7285¹/₂A spring were removed would the non-add key remain depressed?
37—What part if removed would cause an amount to be added and a non-add symbol printed when the non-add key is depressed?

7300 Section

This section expands the 1-7380A springs on the forward stroke to furnish power to operate the machine on the return stroke and operates the 7800 section through the medium of the 1-7381A springs on the forward stroke and directly on the return stroke.

The ribbon and carriage mechanisms receive their movement by being directly connected with the 7300 section.

The 1-7320A is made up of the notched plate 1-7311A and the link 1-7320A.

The 1-7311A is fastened rigidly to the shaft 7301A (in 1-7301A) and this part acts as a limit on both the forward and return stroke of the machine. The notches are engaged by the full stroke pawl 1-7396¹/₂.

The link 1-7320A is connected to the 1-7311A with a stud which is riveted in the 1-7311A and by a long slot with the stud 7350A (in 1B-7300B). This slot prevents forcing the return stroke of the machine. The round hole in the end of the slot allows the 7320A to be disconnected from the 1B-7300B when the machine is held in a forward position.

The main operating springs are connected to the arms 1-7312BR of the 1-7301A and the 7620A (in 1-7065A).

The arms 1-7312BL and BR are connected to the toggle section 1-7312¹/₂B which prevents the return of the arms 1-7312BR and BL until released by the 1A-7312¹/₄ (toggle break).

The 1A-7312¹/₄ moves freely on the 7301A shaft (in 1-7301A) between the arms 1-7312BR and BL. The lower end is connected to the 7800 section by the pitman 7395A. The upper end is connected with the arms 1-7312BR and BL by the secondary springs 1-7381A. The stud 7354¹/₂B in the upper part of 1A-7312¹/₄ engages the toggle detent 7322A which releases the toggle 1-7312¹/₂B.

Adjustments

The toggle detent 7322A should not be released by the 1A-7312¹/₄ until the hammers have been released. The timing of the toggle break is controlled by adjusting the detent

7300 SECTION

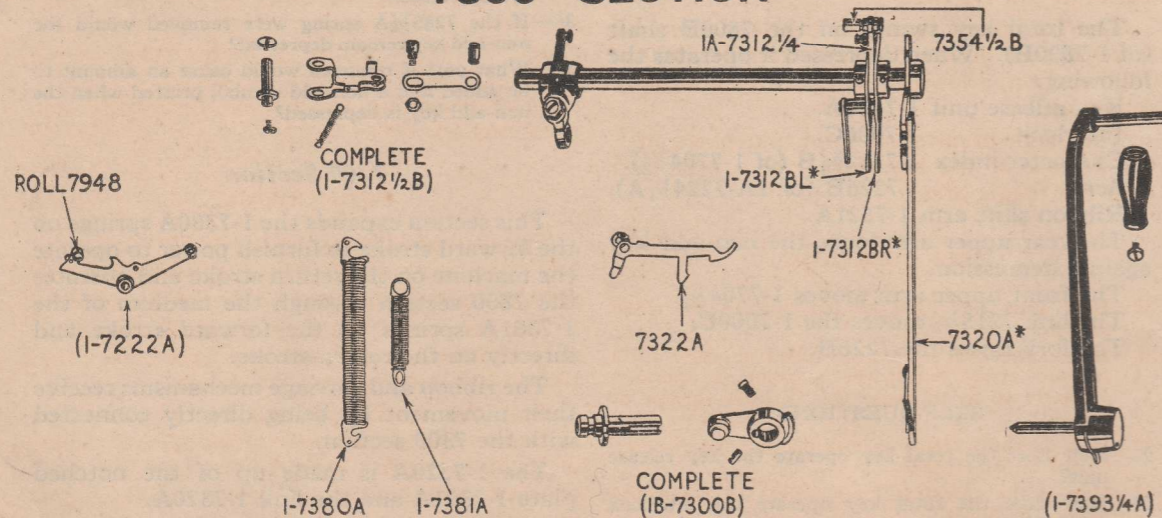

7500 SECTION

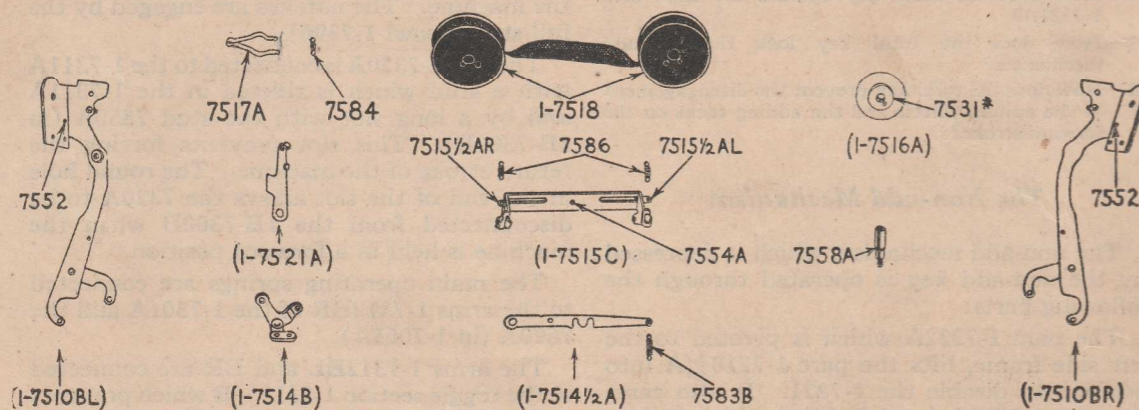

7700 SECTION

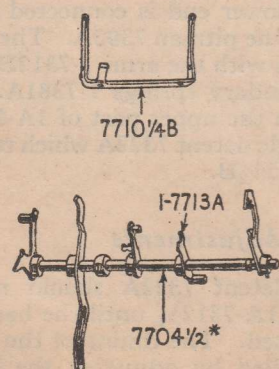

7800 SECTION

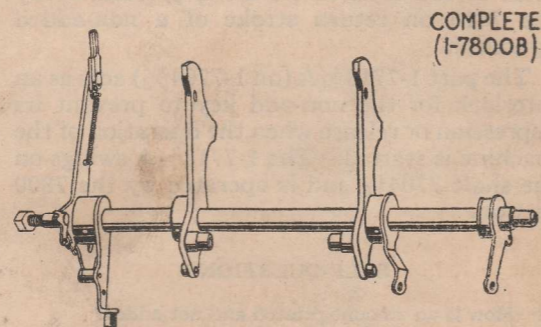

7322A for earlier or later contact with the stud 7354 $\frac{1}{2}$ B (on 1A-7312 $\frac{1}{4}$).

Test for proper timing of toggle, depress all 9 keys, pull handle forward and detain the 7800 section, allowing the latter to gradually follow up.

The toggle break should not take place until the release of the hammers has a safe lead over the toggle break.

SELF-QUESTIONS

- 38—How does the 7300 section operate the 7800 section?
- 39—How is the 7300 section controlled to insure a full forward stroke when the machine is operated violently so as to cause the 1-7381A springs to expand?
- 40—How do the 1-7380A springs operate the machine on the return stroke?
- 41—How is the operating lever 1-7393 $\frac{1}{4}$ A connected to the 1B-7300B?
- 42—What is the purpose of the long slot in the link 7320A?
- 43—How is the link disconnected from the 1B-7300B?
- 44—What limits the forward stroke?
- 45—What limits the return stroke?
- 46—What is the test for the correct timing of the toggle break?
- 47—What adjustment is made in order to secure a later or earlier release of the toggle?

Section 7500 Ribbon Mechanism

The ribbon spools 1-7518 revolve on the posts 7558A which are fastened rigidly to the supports 1-7510BL and BR. The ratchets 1-7516A are held and revolve on the lower part of the posts 7558A. The hubs 7531 (of 1-7516A) have projecting pins that engage holes in the spools.

The bands 7517A and springs 7584 which are around the hubs 7531 (of 1-7516A) prevent the drag of the pawls 7515 $\frac{1}{2}$ AR and AL turning the 1-7516A. The bands are held stationary by the studs 7552 (in 1-7510BR and BL).

The ratchets 1-7516A are revolved alternately by the pawls 7515AR and AL which are carried by the slide 1-7515C. The length of the slide allows only one ratchet to be engaged at a time. The slide 1-7515C is given an oscillating movement by the intermediate slide 1-7514 $\frac{1}{2}$ A, through its connection with the bell crank lever 1-7514B.

The intermediate slide 1-7514 $\frac{1}{2}$ A has two small pockets which alternately engage the stud 7554A (in 1-7515C). When the ribbon has

been entirely unwound from one of the spools, the slide 1-7515C becomes locked, and then the positive movement of the intermediate slide 1-7514 $\frac{1}{2}$ A causes the engagement of its other slot with the stud 7554A (in 1-7515C) thereby reversing the ribbon movement by revolving the other spool.

Adjustments

The springs 7584 on the bands 7517A should have like tension; this also holds true for the springs 7586 of the pawls 7515 $\frac{1}{2}$ AR and AL.

The tension of the spring 7583B should be only sufficient to prevent a reverse before the ribbon has been entirely unwound.

Test the ribbon reverse by winding the ribbon on one of the spools within 2 or 3 inches of its full length. Operate the machine and observe whether the reverse takes place properly.

SELF-QUESTIONS

- 48—What is the purpose of the bands 7517A?
- 49—When should the ribbon reverse take place?
- 50—How is the ribbon reversal brought about?
- 51—What effect would a weak 7584 spring have on the reverse?
- 52—How is a ribbon tested for the correct reverse?

Ribbon Shift

With machines equipped with two-color ribbons, added items are printed in one color while all items designated by a symbol such as total, sub-total and non-add are printed in the other color.

Depressing the total or sub-total key allows the lever 1-7521A which swings on the 1-7510BL to engage the fork of the lever 1-7713A (on 7704 $\frac{1}{2}$). During the operation of the machine the 1-7510BL is elevated which in turn imparts the same movement to the 1-7510BR through the bail 7710 $\frac{1}{4}$ B, thereby placing the lower half of the ribbon, having a different color, between the type and the paper.

The depression of the non-add key rocks the 7704 $\frac{1}{2}$ shaft through the roll 7948 on 1-7222A and lever 7714A and elevates the lower half of ribbon to the printing position with the same mechanism as the total and sub-total levers.

The extension on the right of the bail 7710 $\frac{1}{4}$ B follows the hammer (1-7715B) resetting arm 1-7728R and on the return stroke

7000 SECTION

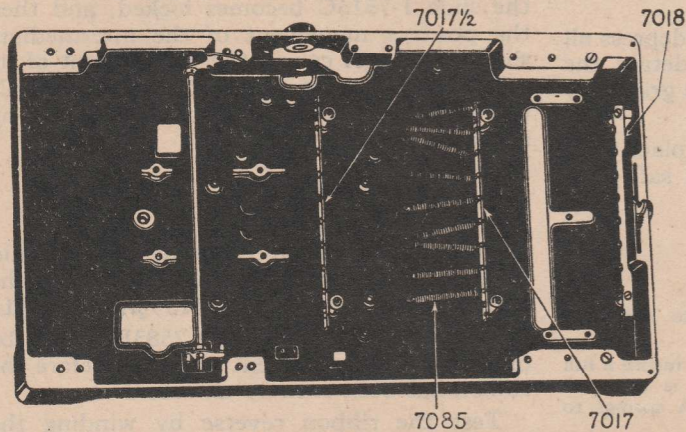

7200 SECTION

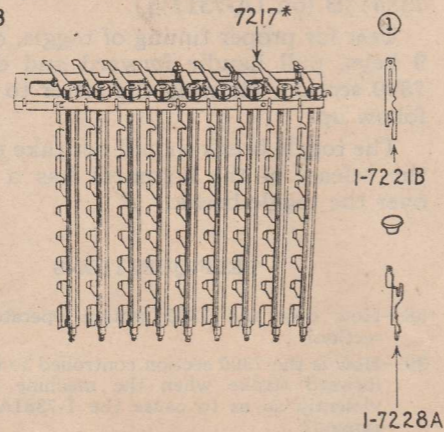

7400 AND 7500 SECTIONS

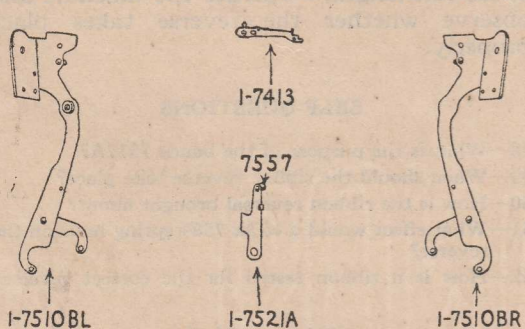

7600 SECTION

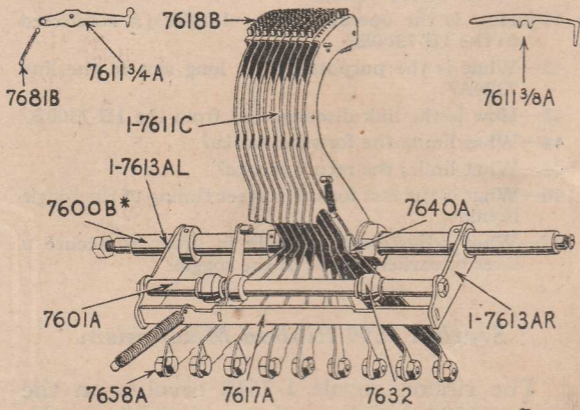

7700 SECTION

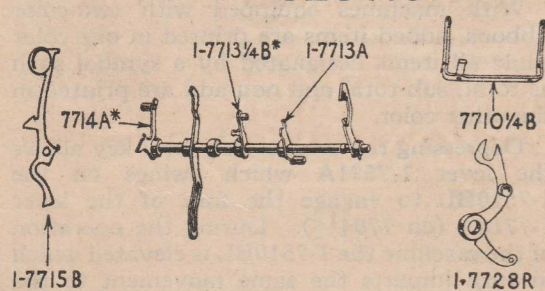

7900 SECTION

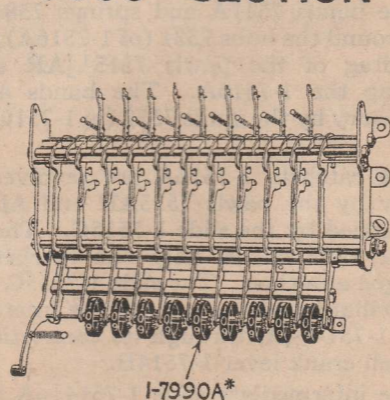

7800 SECTION

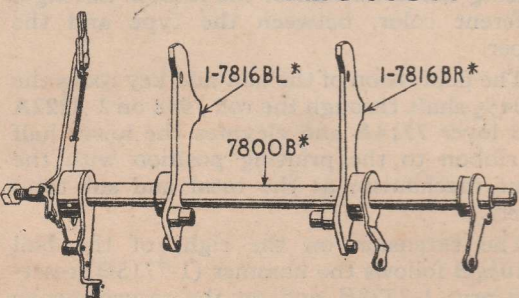

this provides for a positive resetting of the supports 1-7510BR and BL.

Adjustments

The stud 7557 (on 1-7521A) should swing freely into the fork of the 1-7713A.

The stud 7557 should limit in the fork and not against the stud of the arm 1-7713 1/4 B.

SELF-QUESTIONS

- 53—Why is the ribbon shift raised by the total or sub-total keys?
- 54—How do the total and sub-total keys operate the ribbon shift mechanism?

7600 Section

The adding rack 1-7610A carries the front end of the 1-7612A. During the adding process it moves with the 1-7612A and when a carry takes place it moves independently in the slots of the 1-7612A, by tension of the spring 7680A. The anti-friction roll 7645 provides free action, acts as a guide and insures an even mesh with the adding wheel 1-7990A by overcoming the pivotal movement which the type sector 1-7611C communicates to the strip 1-7612A. The 1-7612A has 9 upper projections placed alternately to the left and to the right. When a key is depressed and the machine is operated, one of the projections limits against the keystem. The rear lower projection is engaged by the locking pawl 7217 when the machine is operated without any keys depressed. The stud 7654 in the front upper part of the 1-7612A is engaged by the column release key 1-7228A, when depressed, thereby preventing the movement of the 1-7612A.

The 1-7612A is moved by the spring 7085 and guided by the adding rack 1-7610A, base strips 7017, 7017 1/2 and the 1-7611C. It also moves the type sector 1-7611C through its connection to that part by the eccentric screw 7658A.

The type sectors 1-7611C swing on the shaft 7600B between the circular guides 7640A. Its upper curved part carries the type separated by guide lugs. The type 7618B is held upward and restored after printing by the 7611 3/8 A which lies in the slot of the type and is moved by the lever 7611 3/4 A and the spring 7681B.

On the return stroke the type sectors are restored by the part 7617A which is carried by the arms 1-7613AR and AL (on 7600B). The 7600B is actuated by the cams 1-7816BR and BL (on 7800B) which contacts with the rolls 7632 (on 7601A).

The type is so well supported in its movement in the guides which are integral with the type sector that the alignment is practically permanent.

Total Alignment

By adjusting the eccentric screw 7658A all of the type in a sector are raised or lowered.

If a type requires adjustment it should be removed and replaced.

Test for 1-64" clearance of the 1-7610A and the limit stop 7018.

Test

Register 9's on all adding wheels. Take a total holding the operating lever forward, work the 7900 section in and out of mesh with the adding racks. A slight movement of the type sectors indicates this clearance.

Listing Alignment

The cipher type are aligned by adjusting the 7217.

When the 7217's are adjusted it is highly important to test the excess movement of the stud 7651 1/2 (on 1-7610A) over the 1-7413. The other listing type are aligned by adjusting the upper projections on the 1-7612A which limits against the keystems 1-7221B.

SELF-QUESTIONS

- 55—Why are the rolls 7645 placed on a stationary shaft instead of being fastened to the adding racks 1-7610A?
- 56—What is the function of the stud 7651 3/4 in 1-7610AR?
- 57—What is the function of the small studs on the upper edge of the 1-7612A, located above the spring slot?
- 58—Which projection limits the 1-7612A's when ciphers are printed?
- 59—Why are the projections on the 1-7612A which limit against the keystems placed alternately on each side?
- 60—How are the type sectors restored to the normal position?
- 61—How are all type in one column restored by a single spring?
- 62—How are the type plates 7611 1/8 A held in position?
- 63—Why are the type slotted?
- 64—Why are eccentric screws used to connect the type sectors 1-7611C and the index bars 1-7612A?
- 65—How are the type limited when ciphers are being printed?
- 66—What limits the type sectors during the totaling process?

7200 AND 7300 SECTIONS

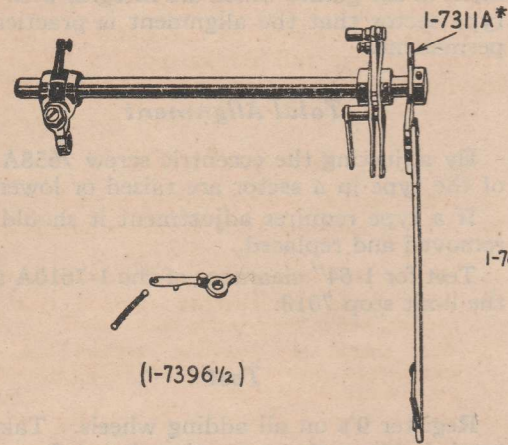

7600 SECTION

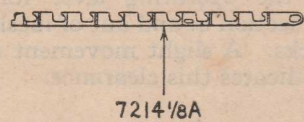
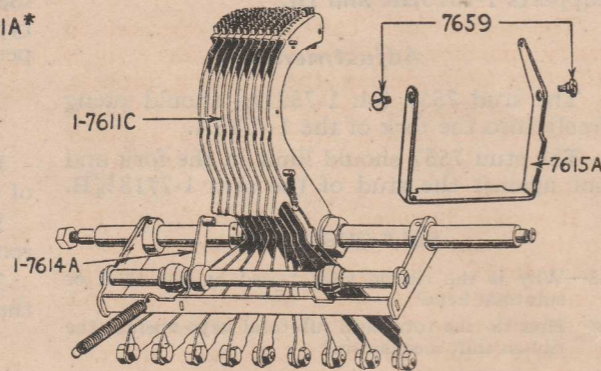

7700 SECTION

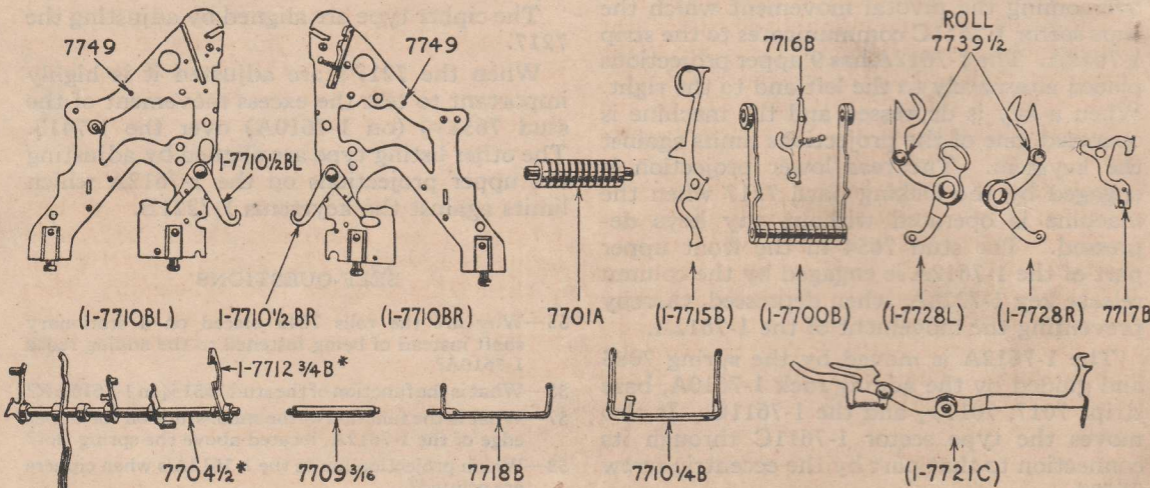
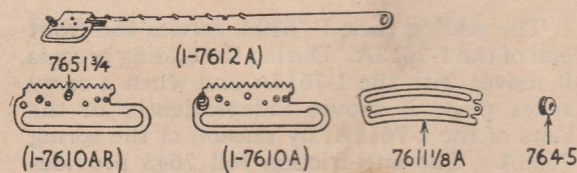

7800 SECTION

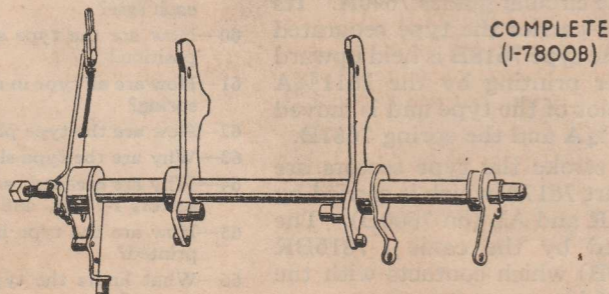

Sector Lock Bail

The sector lock bail 7615A operates at every machine movement. However, it is effective only during the totaling process, when it engages the sectors of those columns in which the adding wheels are in a cipher position. Unnecessary sector movement is eliminated.

It swings between the 1-7710BL and BR in the screws 7659 and engages the hooks on the 1-7611C. The arm 1-7614A engages the cam of the 7615A which is shaped to allow sufficient time for all 1-7611C's to locate properly before the 7615A lock takes effect.

SELF-QUESTIONS

- 67—How is the sector lock bail operated?
- 68—What is the purpose of the sector lock bail?

7700 Section

The main functions of the hammer section are to strike the type that prints, and to operate the space lock which controls the interlock.

The 7700 section assembly includes the ribbon mechanism, the sector lock 7615A, the character index 1-7712 3/4 B (on 7704 1/2 B), hammer block part 1-7721C and 7718B, and the hooks 1-7710 1/2 BR and BL which operate the keyboard lock strips 7214 1/8 A.

This section is operated by the 7800 section to which it is connected by the forked arms 1-7728R and L. These arms swing on the shaft 7701A which carries the hammers 1-7715B. The upper part of these arms carry the shaft 7709 3/16 which resets the hammers and also resets the 7710 1/4 B (of the two-color ribbon shift). The roll 7739 1/2 engages and operates the 1-7700B.

Adjustments

The shaft 7709 3/16 which resets the hammers 1-7715B should clear the hammers at the instant they are released. This clearance should be uniform to prevent light printing of all figures or figures on either side.

The diameter of the shaft 7709 3/16 controls even clearance.

Locating the arms 1-7728R and L control uneven clearance.

Caution—When adjusting arms 1-7728R and L a screwdriver should be placed under the lower part through the side plates 1-7710-BR and BL. When the machine is in normal

position there must also be play between the shaft 7709 3/16 and the hammers 1-7715B.

When 9's are printed the hammers should release as the full stroke pawl 1-7396 1/2 is leaving the second last notch of the 1-7311A.

SELF-QUESTIONS

- 69—Which section operates the 7700 section?
- 70—Are the hammers 1-7715B driven directly by a spring?
- 71—How are the hammers reset after striking the type?
- 72—Why should the resetting medium clear the hammer before the printing takes place?
- 73—Why should the resetting medium hold the hammers for clearance with the 7717B's when they are in a normal position?
- 74—How is even clearance of the resetting medium secured?
- 75—How is more or less clearance of the resetting medium secured?
- 76—When the figures 9 are printed what is the proper position of the full stroke pawl 1-7396 1/2?

7700 Section (7716B)

The 1-7700B unit swings on the 7749 (in 1-7710BR and BL). It carries and moves the intermediate pawls 7716B which disengage the pawls 7717B and the hammers 1-7715B thereby allowing the hammers to strike the type.

If the machine is operated without having previously depressed any keys the type sectors 1-7611C raises and limits the 1-7612A's in cipher position on 7217's, the contact point of the 7716B with the 1-7611C slightly raises with the sector and remaining away from the 7717B pawls preventing the hammers from being released.

Adjustments

The pawls 7716B must move very freely so that they will reset over the hooks of the 7717B when handle is pulled forward to first stop with 9 keys depressed.

Test the free action by pressing each pawl downward and allowing it to return slowly.

SELF-QUESTIONS

- 77—What is the function of the 1-7700B unit?
- 78—How is the printing of ciphers prevented to the left of an amount?
- 79—Why should the pawls 7716B move perfectly free?
- 80—What test is used to determine the free action of the pawls 7716B?

7200 SECTION

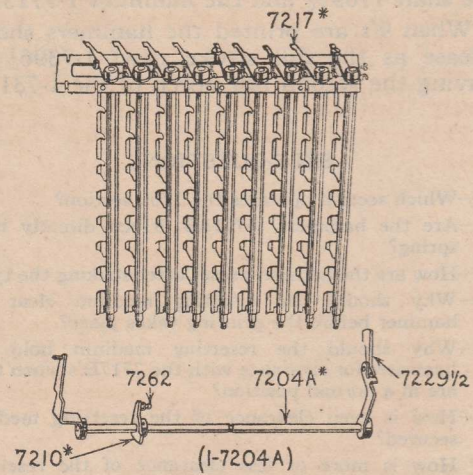

7600 SECTION

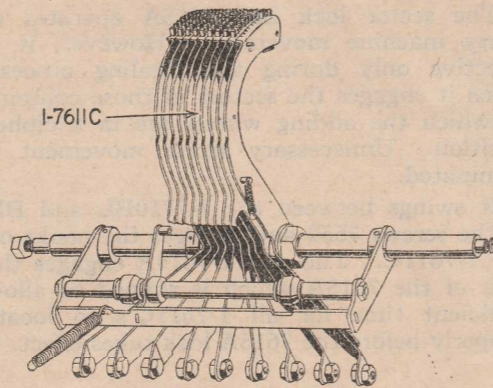

7700 SECTION

COMPLETE SECTION 2-7710B

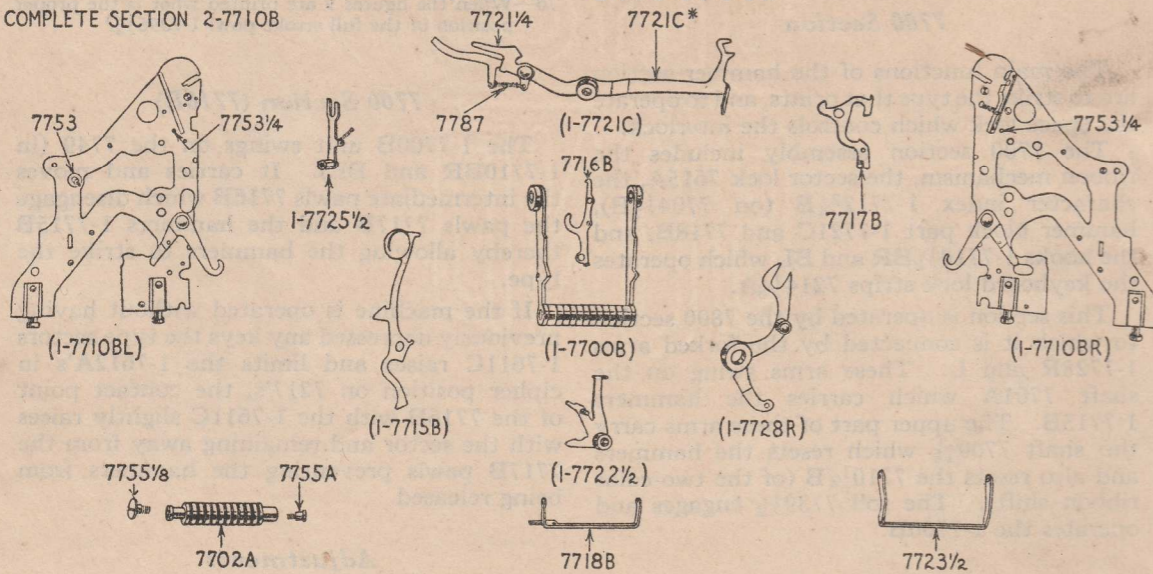

8300 SECTION

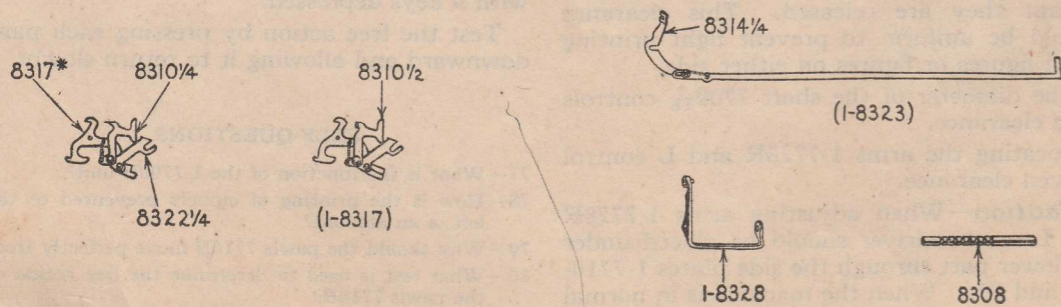

7700 Section (2-7710B)

The pawls 7717B swing on the shaft 7702A which is held in position between the 1-7710BR and BL by the screws 7755A and 7755 1/8. These pawls engage the lower part of the hammers 1-7715B preventing action of the hammers until tripped by the intermediate pawls 7716B. Each 7717B has an overlapping projection which connects with the next 7717B to the right so as to provide for the printing of ciphers. The lower part of the pawls 7717B when tripped move the bail 7723 1/2 to which the arm 1-7725 1/2 is connected. The latter moves the 1-7204A which prevents depression of the total keys until a spacing stroke is taken. The space lock 1-7722 1/2 holds the bail 7723 1/2 rearward until the 1-7728 resets the bail on the following spacing stroke.

Adjustments

The space lock 1-7722 1/2 should clear the

7210 by 1/32" when a spacing stroke is taken. This clearance can be secured by locating the upper arm of 1-7722 1/2 where it contacts with the 1-7728R.

The shaft 7204 (of 1-7204A) should move freely; this also holds true for the fork of 1-7725 1/2 which slides on the stud 7262 (in 7210).

SELF-QUESTIONS

- 81—What are the functions of the pawls 7717B?
- 82—How is the automatic printing of ciphers accomplished?
- 83—How is the 7700 section arranged to print dates without printing a row of unnecessary ciphers?
- 84—What is the purpose of the space lock 1-7722 1/2?
- 85—How is the space lock reset to normal?
- 86—How is the clearance of the space lock 1-7722 1/2 over the 7210 on 1-7204A secured?
- 87—What is the function of the pawl 7229 1/2?

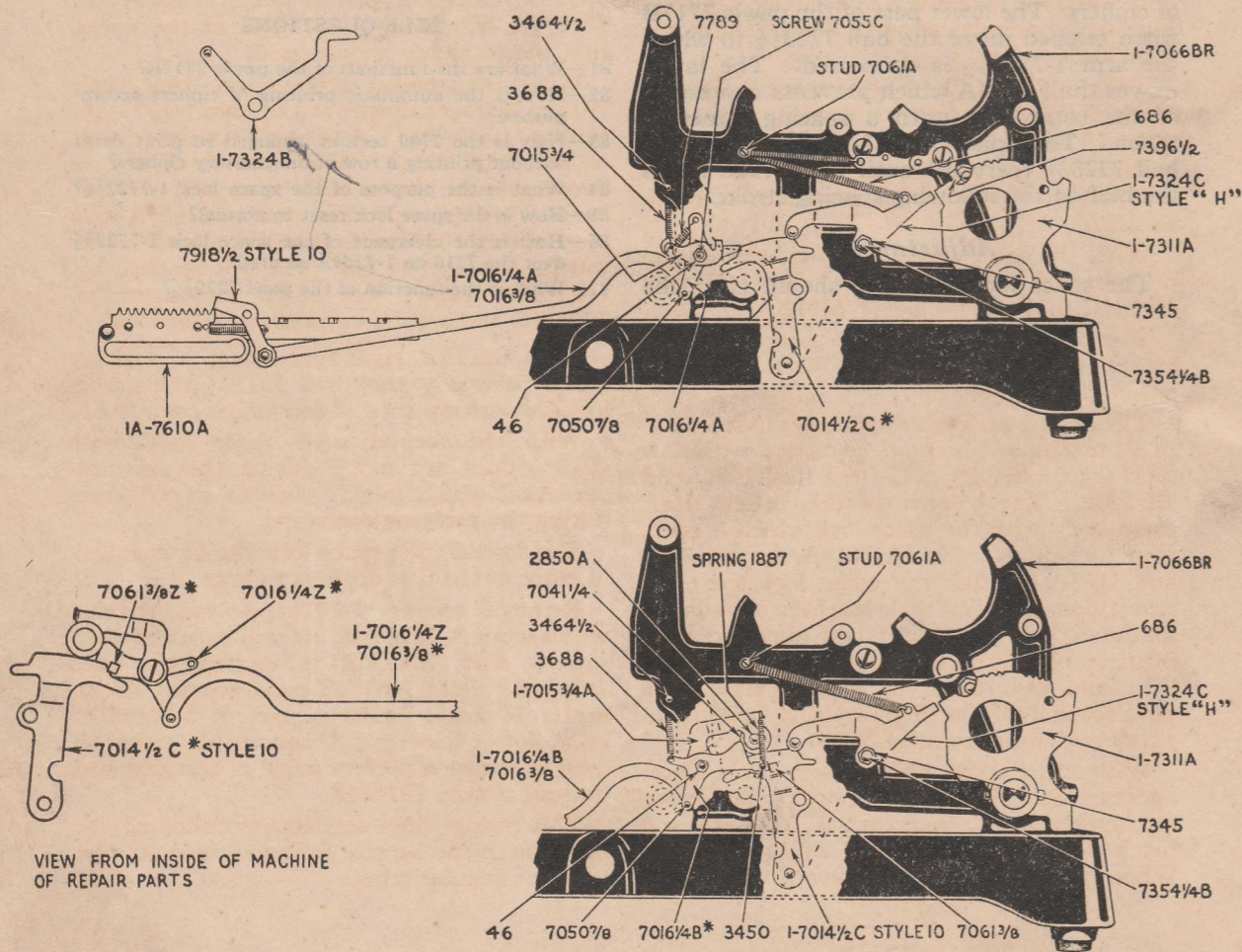

Space Locks

The original style space lock 1-7722 1/2 is operated by pawls 7717B so that a spacing stroke is required before the total keys can be completely depressed irrespective of whether the machine is or is not in a carry position.

The later style space lock is operated by adding racks 1A-7610A when a carry takes place, so that a spacing stroke is necessary only when the machine is in a carried position, in order to permit complete depression of the total keys.

The original and later style space locks both block 1-7311A by preventing complete movement of 1-7014 1/2 C.

With the original space lock this causes 1-7324B to tilt 7396 1/2 in order to block 1-7311A.

With the later style, however, prevention of complete movement of 1-7014 1/2 C tilts 1-7324C to directly block 1-7311A.

The original space lock is used in all machines which are equipped with old style accumulators, 2B-7900.

The adding-rack-operated space lock is used in all machines which are equipped with new style accumulators, 2C-7900, 2D-7900 and 2E-7900. The balance of this article deals exclusively with the space lock which is operated by adding rack 1A-7610A, except 3001 and 3105. Of this later space lock there are two styles. The first style has been abandoned for the second style which is now manufactured. Since some of the first style are still in the field and also that the second style is a development of the first style, a brief comparative description is in order.

With either style, when a carry takes place, adding rack 1A-7610A moves one space further rearward, then one of its teeth will block downward movement of bail 7918 1/2. When bail 7918 1/2 is held upward, the move-

ment of 1-7014 1/2 is limited and neither total key can be fully depressed.

This principle is identical in both styles.

The difference is that in the first style bail 7918 1/2 is moved upward at the beginning of the forward stroke and moved downward at the end of the return stroke.

With the first style, when a carry takes place, bail 7918 1/2 cannot move down, spring 3882 on 7015 3/4 is placed under tension and 7016 1/4 A will block 1-7014 1/2 C in the event that the total key is depressed.

With the second style space lock, bail 7918 1/2 is moved downward by cam 1-7014 1/2 C raising arm 1-7015 3/4 A through the depression of the total keys. When the total key is depressed with the machine in carried position cam 1-7014 1/2 C will raise arm 1-7015 3/4 A and place spring 1887 under tension because downward movement of bail 7918 1/2 is blocked by 1A-7610A which also stops movement of 7016 1/4 B and results in blocking 1-7014 1/2 C.

With the first style space lock, it is absolutely necessary that bail 7918 1/2 remain in upward position until all carrying is completed.

With the second style space lock, bail 7918 1/2 does not move during the machine operation which avoids possible interference during the carrying operation.

The second style space lock can be installed in place of the first style as follows:

Remove section 1-7016 1/4 A and replace with section 1-7016 1/4 Z. It will be noted that square stud 7061 3/8 Z is carried by part 7016 1/4 Z. Stud 7061 3/8 Z must contact about center of angle on front part of 1-7014 1/2 C in a slot 1/16" deep. A square file must be used to insure a perfect angle of the side and bottom of stud 7061 3/8 Z.

This change does not require removing the machine to the Service Station and should be made on regular trips.

7200 SECTION

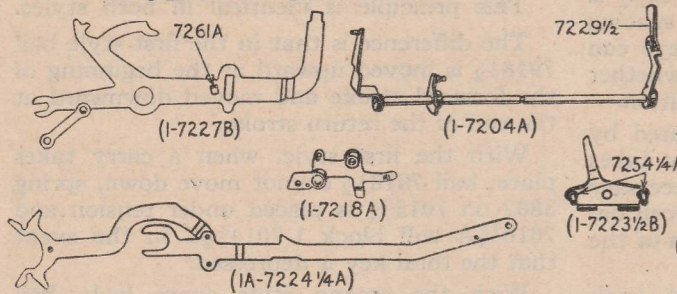

7300 SECTION

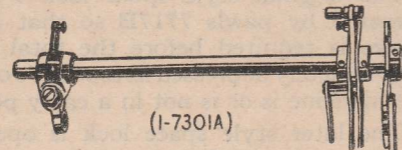

7600 SECTION

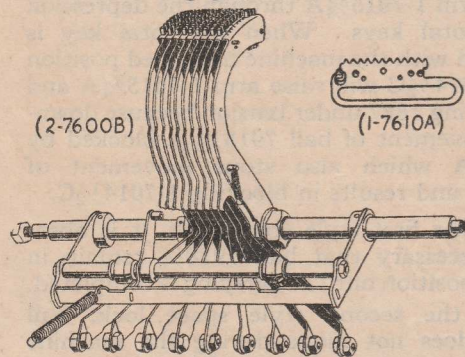

7700 SECTION

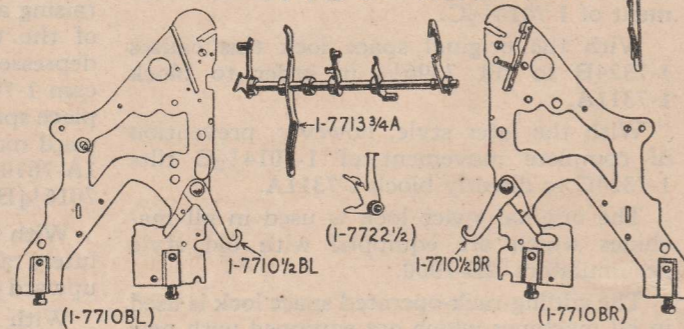

7800 SECTION

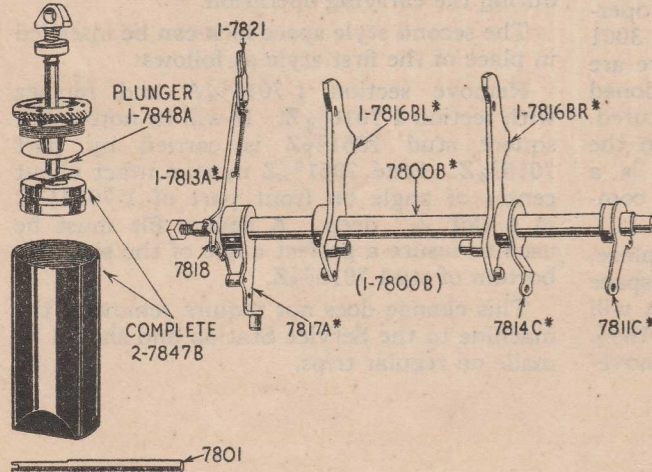

7900 SECTION

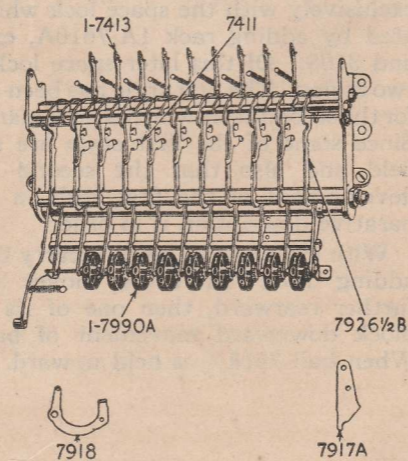

8300 SECTION

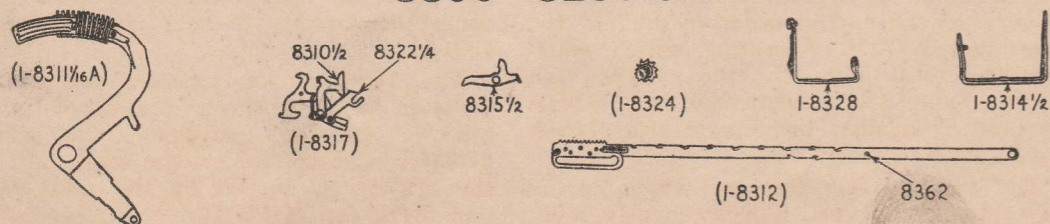

Hammer Block Bail 7718B

The function of the hammer block bail 7718B is to prevent the action of the hammers 1-7715B when the non-print key is depressed or when the carriage has been removed.

The bail 7718B swings on the studs 7753 $\frac{1}{4}$ (in 1-7710BR and BL). The part 1-7721C pivots on the stud 7753 (in 1-7710BL). The carriage when in position contacts with the arm 7721 $\frac{1}{4}$ (on 1-7721C) which is connected to the 7721C by the spring 7787 and causes the 1-7721C to lift the bail away from the hammers.

When the non-print key is depressed it lowers the 1-7721C and expands the spring 7787.

SELF-QUESTIONS

- 88—What are the functions of the hammer block bail 7718B?
 89—What effect has the carriage when in position on the 7718B?
 90—Why is the arm 7721 $\frac{1}{4}$ which is held down by the carriage, connected with a spring to the part 7721C?
 91—How does the non-print key operate the hammer block bail?

S.K.S. Split Unit

The bail 8314 $\frac{1}{4}$ (of 1-8323) connects or disconnects the coupler 8310 $\frac{1}{2}$ on 1-8317. A notch in the bail always allows the coupler between the two date hammers to be connected. The couplers 8310 $\frac{1}{2}$ are carried by the part 8322 $\frac{1}{4}$ which swings on the pawls 8317, the fork of the 8322 $\frac{1}{4}$ slides in the guides of the shaft 8308.

The upper part of 8322 $\frac{1}{4}$ is moved rearward by the depression of the total keys when the machine is in date position by the bail 1-8328, which engages the part 8310 $\frac{1}{4}$. This causes the pawls 8317 to release the hammers before the forward stroke of the machine is started which results in the hammers moving out without striking the date type. Observe that when either of the total keys are depressed when a machine is in split position, the movement of the 8317 causes the 1-7204A to move rearward and in order to prevent the space lock 1-7722 $\frac{1}{2}$ operating, which would lock the total keys, the part 7229 $\frac{1}{2}$ (on 1-7204A) stops the movement of the 1-7204A by limiting against the square stud 7261A (on 1-7227B).

The extreme left column, which carries only character type, is permanently split,

but the next column to the right, which carries both character type and numbered type, is split only when the character type are used, so as to print the ciphers when the numeral keys are depressed.

This result is secured by the bail 1-8314 $\frac{1}{2}$ which swings on the 1-7204A and is controlled by the stud 8362 (in 1-8312). When the character keys are depressed and the machine is operated the bail 1-8314 $\frac{1}{2}$ raises the coupler pawl 8315 $\frac{1}{2}$ which prevents a cipher from being printed. When using the numeral keys the bail 1-8314 $\frac{1}{2}$ cannot raise the coupler pawl 8315 $\frac{1}{2}$ on account of the stud 8362 (in 1-8312) which results in cipher being printed.

When printing totals, stud 7651 $\frac{3}{4}$ (in 1-8320 $\frac{1}{2}$ A) contacts under part 8315 $\frac{1}{2}$, disabling bail 1-8314 $\frac{1}{2}$, which allows ciphers to print after numerals and characters.

During a totaling process the movement of the S.K.S. type sector 1-8311 $\frac{1}{16}$ A is prevented by the cam wheel 1-8324.

The 1-7413 stops the cam wheel on the forward stroke.

SELF-QUESTIONS

- 92—What is the purpose of the coupler 8310 $\frac{1}{2}$ which is attached to the 1-8317?
 93—Why is the bail 1-8314 $\frac{1}{4}$ which raises the couplers 8310 $\frac{1}{2}$ cut out on top?
 94—What is the purpose of the fork on the part 8322 $\frac{1}{4}$?
 95—Why is the part 7229 $\frac{1}{2}$ necessary in S. K. S. machines?
 96—Why is the column next to the extreme left column split when characters are printed?
 97—Why is the column next to the extreme left column coupled when numbers are printed?
 98—Referring to the last question, how are these results accomplished?
 99—How is the non-printing of S. K. S. characters during the total process secured?

7800 Section

The 7800 section controls the movement of all sections on the forward and return strokes with the exception of the ribbon and carriage movement on the forward stroke, which are connected directly to the 7300 section (1-7301A).

The 7800 section includes the dashpot 1-7847B which controls the speed of the machine on both strokes. The plunger 2-7848A is suspended on the shaft 7801 and the cylinder is carried by the arms 7814C and 7811C (on 7800B).

The cams 1-7816BR and BL are carried on the shaft of 7800B (of 1-7800B). The function of these cams is to operate the 2-7600B on the return stroke.

The lower extension of these cams operate the 7700 section and the hooks 1-7710 $\frac{1}{2}$ BR and BL (on 1-7710BR and BL).

The flipper pawl 1-7821 which oscillates the 7917 is pivoted on the 1-7813A. The latter part is carried by the 1-7800B which also releases the non-add key mechanism by the flipper pawl 7818 which is pivoted on an extension of the 1-7813A.

The arm 7817A (on 1-7800B) operates the key restoring unit 1-7218A and also the non-add key interlock 1-7713 $\frac{3}{4}$ A.

SELF-QUESTIONS

- 100—Which sections do the 7800 section operate?
 101—Why does the 7800 section control only the ribbon and carriage mechanisms on the return stroke?
 102—Which section furnishes the power that moves the 7800 section?
 103—How does the dashpot control the speed of the machine?
 104—What is the function of the cams 1-7816BR and BL?
 105—What part of the 7800 section operates the 7700 section?
 106—What is the function of the 1-7821?
 107—What is the function of the 7818?
 108—What are the functions of the arm 7817?

Sequence of Timing Operation Forward Stroke

- A Sectors and racks index.
 B Hammer release.
 C Lead of 1-7821A over upper stud 7254 $\frac{1}{4}$ A.
 D Toggle break.
 E Full stroke pawl 7396 $\frac{1}{2}$ A leaves 1-7311A.

Return Stroke

- F Lead of 1-7821A over lower stud 7354 $\frac{1}{2}$.
 E Full stroke pawl 7396 $\frac{1}{2}$ A leaves 1-7311A.

Sequence of Timing Tests

- A Oil level 1 $\frac{1}{8}$ in. from top of dashpot with plunger removed.

Speeds

		Hand Speed	Motor Speed
Class 3			
Style 5		155—165	
Narrow	7	155—165	
Wide	7	135—145	135—145
	9	135—145	135—145
	10	135—145	135—145
Class 4			
Style 9		135—145	130—140
	10	135—145	130—140

EE Relative position of full stroke pawl 7396 $\frac{1}{2}$ A and 1-7311A is .010" clearance between 7396 $\frac{1}{2}$ A and 1-7311A at the end of forward and return strokes.

This is a fixed factory adjustment. When the machine is hand operated this test must not be changed for the reason that 1-7311 (which is the limiting point) is directly connected with the operating handle.

C Relative position of 1-7821 and 1-7311. 1-7821A should pass upper stud 7254 $\frac{1}{4}$ A (in 1-7223 $\frac{1}{2}$ B) slightly before or at the time 7396 $\frac{1}{2}$ is on peak between second last and last notch of 1-7311A. This relative position is located when shaft unit 1A-7301A is assembled. When replacing 1-7311A this test must be strictly adhered to. If for any reason this relative position is out of test, shaft unit 1A-7301A must be replaced.

B Hammers 7715 should release when 7396 $\frac{1}{2}$ A is between the front and the rear peaks of the second last notch of 1-7311A. This flexibility of hammer release is required for the reason that hammer release takes place earlier when no ciphers are being printed. Hammer release is also earlier in machines having smaller column capacity and later in machines having larger column capacity.

Adjustment: Advance or retard 1-7729A contact on roll 7739 $\frac{1}{2}$ (on 1-7728R and L) by locating projection on 1-7729A.

When this adjustment has been made, pull handle forward and test for equal contact on rolls 7739 $\frac{1}{2}$.

C 1-7821A should drop off upper stud 7254 $\frac{1}{4}$ A (in 1-7223 $\frac{1}{2}$ B as 7354 $\frac{1}{2}$ contacts on 7322A).

1-7821A should have $\frac{1}{8}$ " lead over the upper stud in 1-7223 $\frac{1}{2}$ B as the toggle breaks. (Test by holding up 7800 section.)

Adjustment: Advance or retard rear arm of 7322A contact on stud 7354 $\frac{1}{2}$ B (in 1A-7312 $\frac{1}{4}$).

D Toggle break should allow sufficient hold of toggle to cause a slight bind when operating handle is rocked back and forth.

Adjustment: Advance or retard toggle break as outlined under "C."

7918A must be in normal position on return stroke of totaling operations before 1-7396 $\frac{1}{2}$ A leaves 1-7311A. This is necessary to insure meshing of accumulator and adding racks 1A-7610A.

Adjustment: Stud 7253 $\frac{3}{8}$ is advanced toward lower part of 1-7813A by locating the lower prong of 9224 $\frac{3}{4}$. This adjustment is limited by minimum play between 7253 $\frac{3}{8}$ and 1-7813A when the machine is normal.

Machines of earlier manufacture do not have a prong on 9224 $\frac{3}{4}$, stud 7253 $\frac{3}{8}$ being set in solid metal.

Adjustment: Sufficient stock must be removed from front lower part of 7918A to allow it to meet above test.

Caution: The proper curve on lower part of 7918A must be retained to insure smooth action of 7918A.

Keys 7221 should restore before flapper 1-9219 $\frac{1}{4}$ leaves roll 7841 (on 7817A).

Adjustment: For more hold of 7841 on 1-9219 $\frac{1}{4}$ locate 7817A toward center of machine.

7200 SECTION

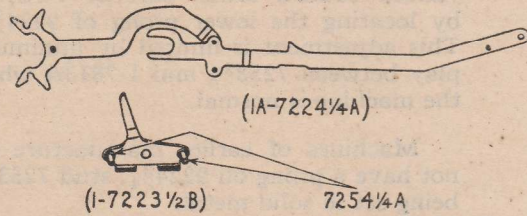

7600 SECTION

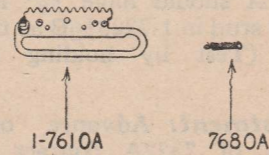

7900 SECTION

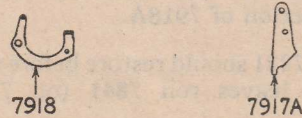
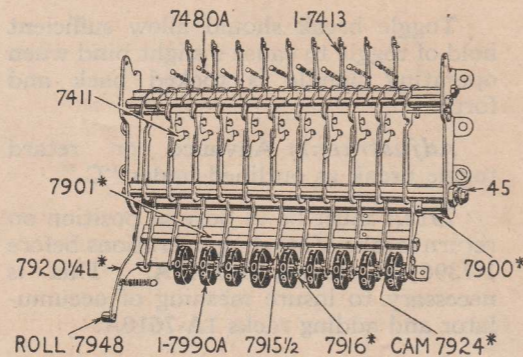

ACCUMULATOR ADJUSTMENTS

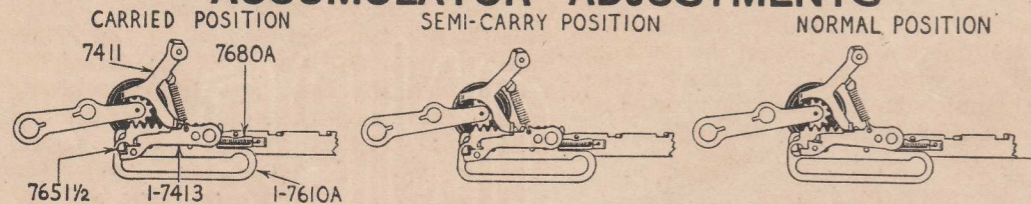

CLEAR MACHINE, DEPRESS ALL 9 KEYS, ADD TWICE, CLEARANCE SHOWS BETWEEN END OF 1-7413 AND 7651 1/2

WITH 7680A SPRING STRAIN REMOVED AND 7411 SLIGHTLY RAISED, THE 1-7413 LIMITS ON THE 7651 1/2. THE MOVEMENT OF THE 1-7413 FROM "CARRIED POSITION" TO "SEMI-CARRY POSITION" INDICATES THE AMOUNT OF CLEARANCE

TURN LEFT ADDING WHEEL UNTIL 1-7413 RESETS. THE MOVEMENT OF THE 1-7413 FROM "SEMI-CARRY POSITION" TO "NORMAL POSITION" INDICATES THE HOLD OF 1-7413 ON 7651 1/2

GAUGE TO TEST 1-7413 HOLD

7900*

GAUGE TEST FOR 1-7413 HOLD

READING IS MADE WITH MACHINE IN NORMAL POSITION, CIPHERS IN ACCUMULATOR SECTION.

WITH INDICATOR SLIDE RAISED, PLACE GAUGE IN POSITION WITH FOOT UNDER THE 7651 1/2 STUD, THEN DEPRESS SLIDE UNTIL IT RESTS ON THE 1-7413. IF THE 1-7413 IS MOVED WHILE PLACING GAUGE, MOVE LEFT WHEEL SUFFICIENT TO RESTORE IT

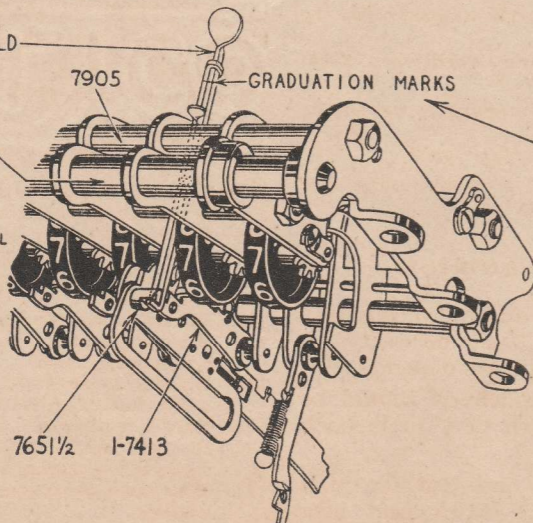

A FULL .045" HOLD IS INDICATED WHEN THE GRADUATION MARKS ARE EVEN

7400 and 7900 Sections

The Class 3 accumulating section is a complete assembly of all 7400 and 7900 parts.

The adding wheels 1-7990A are meshed with the adding racks 1-7610A by moving the frame which carries them downward. When the adding wheels are raised they are disengaged from the adding racks and locked by the detents 7926 1/2.

The carry pawl detents 7411 when tripped, are reset on a spacing stroke by the movement of the frame that carries the adding wheels when they are disengaged from the adding racks.

The 1-7821 controls the raising and lowering of the adding racks through the 1A-7224 1/4 A and the 7917A by engaging the studs 7254 1/4 A in 1-7223 1/2 B.

The part 7917A is moved backward and forward by the 1A-7224 1/4 A. On the forward stroke the arm 7920 1/4 L is released by the 7917A which disengages the adding racks and the adding wheels. On the return stroke the part 7917A cams the arm 7920 1/4 L downward engaging the adding wheels with the adding racks.

The part 7918 is an auxiliary to the part 7917A. Its function is to detain the meshing of the adding wheels and the adding racks until the hammers have cleared the type when figure 1's are printed during a total operation.

SELF-QUESTIONS

- 109—Why is the 1A-7224 1/4 A engaged with lower stud (7254 1/4 A in 1-7223 1/2 B) during a listing operation?
- 110—How are the adding wheels meshed with the adding racks?
- 111—How are the adding wheels locked when disengaged from the adding racks?
- 112—Which part operates the meshing of the adding wheels and adding racks?
- 113—What is the purpose of the part 7918?
- 114—How are the detents 7411 reset after they have been tripped during a carry?

Accumulator Adjustments

A correct mesh of the adding wheels and the adding racks is the basic necessity on which all the other adjustments depend.

The mesh of all adding wheels should be even and non-binding, with very little backlash.

Depress all No. 9 keys and test for play between the 7916 and 1-7610A and arm

7920 1/4 L by depressing the rack as wheels revolve from figure to figure on the return stroke; to test on forward stroke take a total stroke with No. 9's in adding wheels.

Note: Bend 7920 1/4 L for adjustment.

With the accumulator in position the frame which carries the adding wheels must be parallel. This is indicated by an even mesh of the extreme right and left adding wheels, first with the handle normal, and then with handle forward, rack depressed.

To adjust this frame loosen the nuts 45 on both sides and place a screwdriver under each end of the shaft 7901 and by using the 7900 shaft as a fulcrum locate the frame so that all wheels will have an even mesh with the adding wheels.

With the 7900 section removed and the springs 7480A unhooked, see that the detents 7411 move freely and that they align with the parts 7915 1/2, the 7413 are free and the 1-7990A revolve freely.

Hook up 7480A and see that the carry pawl 1-7413 provides a good side hold for the cams 7924 and clear the dials 1-7990A.

Test the clearance of the detent 7411 over the 1-7413 by resetting all detents (7411) which is accomplished by pushing the 7917A under the roll 7948 (on 7920 1/4 L), lifting the 1-7413 with the cam 7924 by turning the adding wheel until the point of the cam has raised the 1-7413 full distance. There should then be about 1/64" clearance between the 1-7413 and 7411. To secure either more or less clearance, peen the 1-7413.

The test for clearance between the cam 7924 and 1-7413 by placing the roll (on 7920 1/4 L) on the 7917A, revolving adding wheels until cams (7924) contact with the 1-7413's then lower and raise the 7920 1/4 L on 7917A and see that 7924 clears 1-7413 by 1/32".

SELF-QUESTIONS

- 115—In order to properly adjust the 7900 section, what is the important adjustment to be made?
- 116—What is meant by an even mesh?
- 117—How is an even mesh indicated?
- 118—How is the adjustment made that will secure an even mesh?
- 119—What is a non-binding mesh?
- 120—What adjustment is made in order to insure a non-binding mesh?
- 121—What tests should be applied to the detents 7411 when the section is removed?
- 122—Why is it necessary to test for clearance between the 7916 and 1-7610A and arm 7920 1/4 L at each figure of the adding wheel?
- 123—Why make the above test on the return stroke of handle?

ACCUMULATOR ADJUSTMENTS

CARRIED POSITION

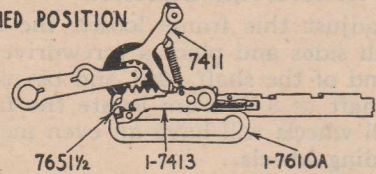

NORMAL POSITION

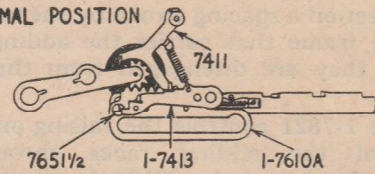

7924* IN '9' POSITION

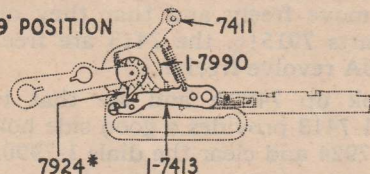

CLEAR MACHINE, RESTORE ADDING WHEELS TO '9' POSITION. THERE SHOULD BE 1/32" CLEARANCE BETWEEN CAM 7924* AND FOOT OF 1-7413

7924* IN '0' POSITION

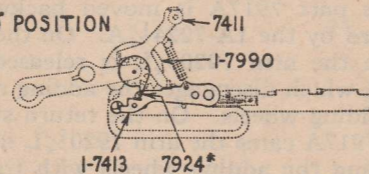

CLEAR MACHINE, ADDING WHEELS IN CIPHER POSITION, THERE SHOULD BE 1/64" CLEARANCE BETWEEN FLAT SIDE OF 7924* AND FOOT OF 1-7413

Accumulator Adjustments (1-7413)

With the 7900 section in position, test the hold of the 1-7413 on the stop 7651 1/2 (on 1-7610A) and the clearance between 1-7413 and bottom of stop 7651 1/2 when a carry takes place.

To test—add all 9's twice so as to have all carry pawls in a tripped position. Pass the left index finger lightly over the top of the second adding wheel to remove the (7680B) spring strain from the first carry pawl, watch movement of 1-7413 through opening between 7900 and 7905 shafts and slightly raise the 7411 so as to limit the 1-7413 on the bottom of the stop 7651 1/2; the clearance is indicated by the movement of the 1-7413. Now turn the adding wheel backward until the 1-7413 resets, which movement is the amount of hold that the 1-7413 has on the stop 7651 1/2.

Hold or clearance can be secured by peening the foot of the 7411 that contacts with the 1-7413, to raise or lower the 1-7413 as the 7411 limits the 1-7413 in both normal or carrying positions.

Note: Increasing the hold decreases the clearance and vice versa.

The hold should be .045 and the clearance .025 so that the movement as indicated by the hold should be almost double the movement indicated by the clearance.

SELF-QUESTIONS

- 124—What adjustment is made on the 7411 to get more hold on the 7651 1/2?
- 125—What tests should the pawls 1-7413 meet when the section is removed?
- 126—How much should the pawl have on the stud 7651 1/2 (on 1-7610)?

- 127—How much clearance should there be between the pawl 1-7413 and the stud 7651 1/2?
- 128—How much clearance should there be between the pawl 1-7413 and the stud 7651 1/2 when a carry takes place?
- 129—How can hold and clearance of the stud 7651 1/2 on 1-7610A and the pawl 1-7413 be observed?

1-7413 Tests

With the 7900 section in position test for clearance of the cam 7924 and the 1-7413 with the adding wheels in 9 position. This can be readily observed by passing the finger lightly over the next adding wheel and raising the 7411 which causes the 1-7413 to follow up until it contacts with the 7924. The movement of the 1-7413 indicates the clearance.

Test for clearance of the 7924 over the top of the foot of the 1-7413 ciphers in. Test one adding wheel at a time by operating the machine with a *slight* rearward finger pressure on the adding wheel. Sufficient clearance will prevent tripping of the pawls 1-7413.

Test for proper hold of the cam 7924 on the foot of the 1-7413 by adding 9's then one, holding space lock out of position and take rapid sub-total with machine in carried position. Side hold as well as proper length of hold is necessary.

SELF-QUESTIONS

- 130—How is the clearance indicated between the 1-7413 and the cam 7924 (on 1-7990) with adding wheel in 9 position?
- 131—Which test indicates clearance of the cam 7924 over the top of the 1-7413?
- 132—Which test will determine proper hold of the cam 7924 on the 1-7413 during a sub-totalling operation?

2D-7900 ACCUMULATOR

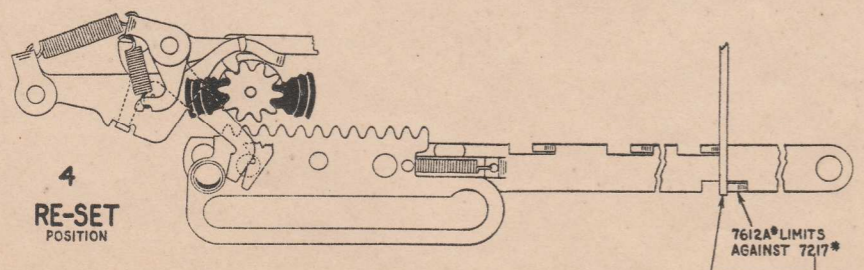
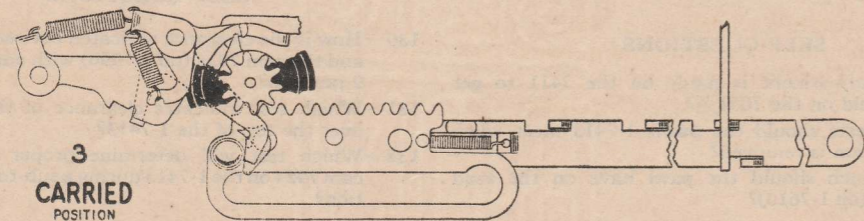
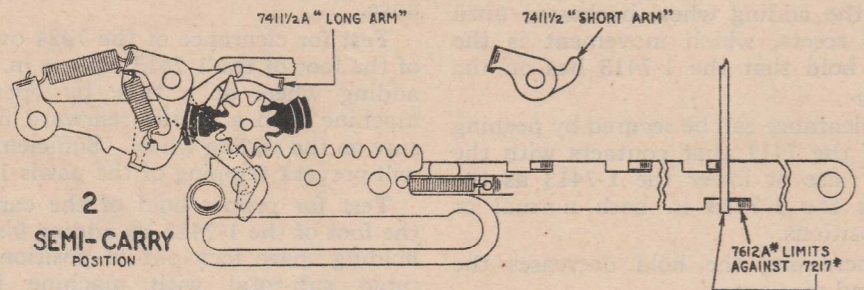
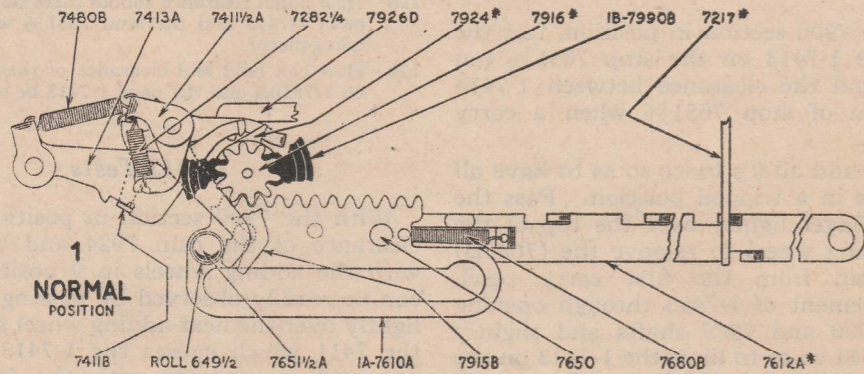

Class 3 Accumulator 2D-7900

7413A

The carry pawls (7413A) in section 2D-7900 move up and down with the adding wheels when they are either meshed or not meshed with the adding racks. Pawl 7413A does not come into direct contact with adding rack 1A-7610A, as it does in section 2B-7900; its function is to release or hold detent 7411B. Detent 7411B limits adding rack 1A-7610A when a carry has not taken place. (See Cut 1.)

Part 7411 1/2 A drives 7411B through spring 7480B which is placed under tension when cam 7924 lifts 7413A. (See Cut 2.) Part 7411 1/2 A also resets 7411B through spring 7282 1/4 which is placed under tension when 7411 1/2 A contacts with 7926C. (See Cut 4.) The adjustments of the carry pawls in this section are more simple and less in number when compared to section 2B-7900.

Adjustments

Mesh of adding wheels and 7926C, forward stroke. (Fig. 4.) There should be 1/64" clearance between 7916 and 1A-7610A, minimum play of any 7916's and all 7926C's tight. This adjustment is secured by locating 7926C's upward or downward.

Return Stroke

Mesh of adding wheels and adding racks, even and non-binding, minimum back lash. (Fig. 1.) This adjustment is secured by bending arm 1-7920 1/4 AL. (See page 23.)

Free action and clearance from other parts. Full side hold for 7924 when totaling. 1/64" clearance between 7924 and 7413A with 9's on dials when 1A-7610A limits on 7411B and also on 7915A.

1/64" clearance between 7413A and 7924 with ciphers on dials.

7411B

Free action.

Alignment for hold on 649 1/2.

1/64" clearance between 7413A and 7411B when 7924 raises 7413A. (Fig. 5.)

1/6" advance of 7411B when 7413A is tripped before 649 1/2 contacts with 7411A. (Fig. 2.) The projection which contacts on 7411 1/2 A is raised or lowered for more or less advance.

1/64" clearance between 7411B and 7413A when resetting on forward stroke, ciphers on dials. (Fig. 4.) This clearance or excess is secured by adjusting 7217 or by installing late style 7411B.

7411 1/2 A

Side clearance from 7926C.
Free action.

General

All stationary parts must be tight. Moving parts must have free action and clearance from other parts. Springs must have correct tension and properly formed eyes.

2E-7900 ACCUMULATOR

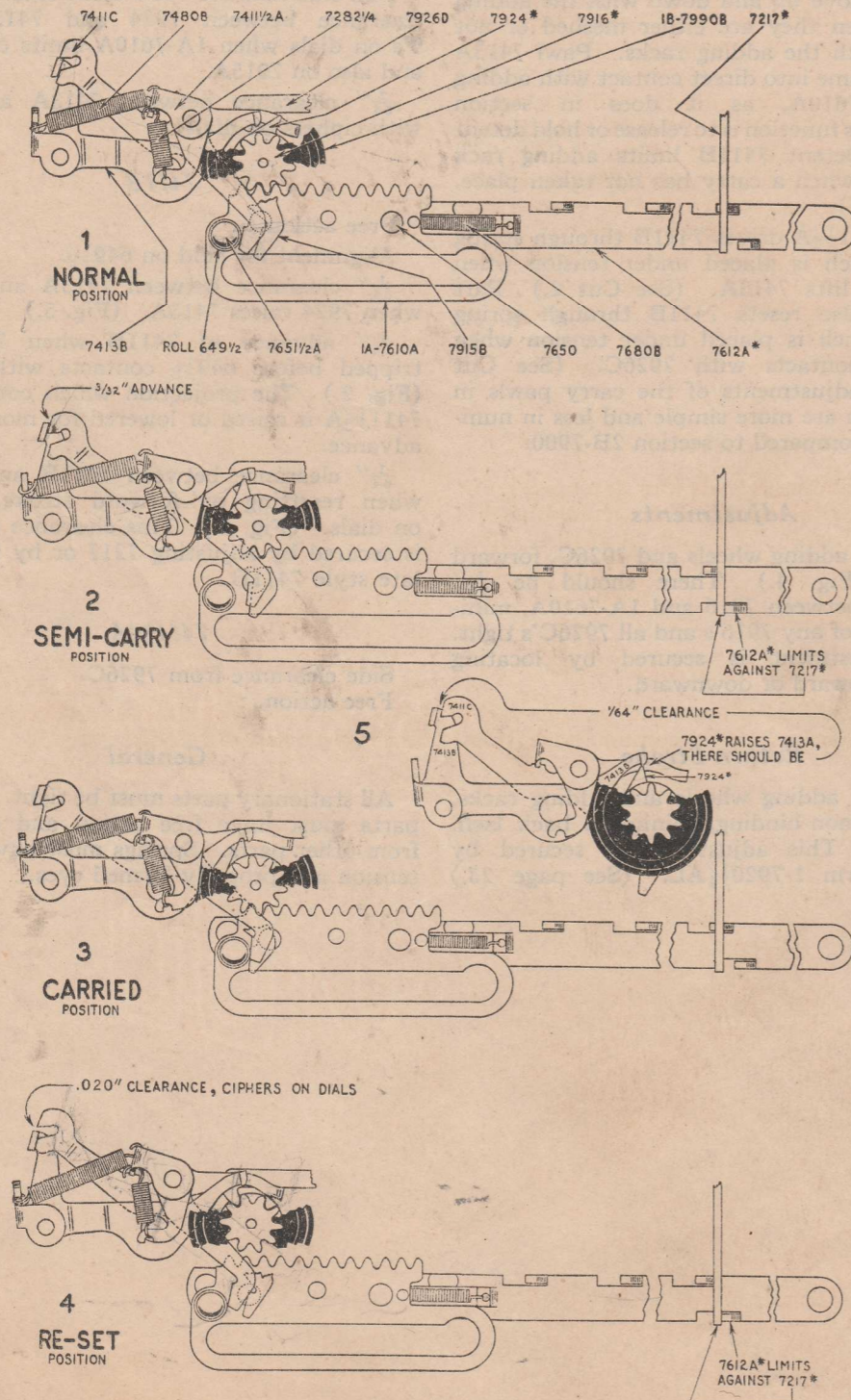

Section 2E-7900

Section 2E-7900 is further development of section 2D-7900. The contact surfaces of pawls 7413B and 7411C are above the section instead of below as in the other sections.

This construction affords visibility when testing pawls 7413B and 7411C for correct adjustment. On account of the longer arm of 7411C which contacts on 7413B, excess or lead is increased when 7411C is resetting after a carry. The arm on which roll 649½ (on 1A-7610A) contacts is blunt instead of pointed. This increases the clearance between 7413A and 7411C during resetting after a carry.

This change has also been applied to 7411B.

Adjustment

Mesh of adding wheels and detents 7926D forward stroke (Fig. 4.) There should be 1/64" clearance between 7916 and 1A-7610A, minimum play of all 7916's and all 7926D's tight. This adjustment is secured by locating 7926D's upward or downward.

Return Stroke

Mesh of adding wheels and adding racks even and non-binding, minimum back lash.

This adjustment is secured by bending arm 1-7920¼L. (See page 23.)

7413B

Free action and clearance from other parts. Full hold for 7924 when totaling. 1/64" clearance between 7924 and 7413B with 9's on the dials when 1A-7610A limits on 7411C and also on 7915B. This adjustment is made by shortening or lengthening the offset on 7411C.

Note: When making this adjustment test for 1/16" clearance between 7413B and 7411C when 7924 raises 7413B. When these tests fail to indicate the correct amount of clearance pawl 7413B should be replaced.

1/64" clearance between 7413B and 7924 with ciphers on dials 7411C should align for correct hold on roll 649½.

.020" clearance between 7411C and 7413B when resetting on forward stroke (Fig. 4.) This clearance or excess is secured by adjusting 7217 or by installing late style 7411C. When a late Style 7411C is installed and excess can not be secured by adjusting 7217 the rear arm of 7411½A is bent upward.

Note: 7411½A must not be bent upward to the extent of causing a hard carry, since 7411½A locates 7411C when 7413B is tripped during accumulation (semi carry.)

8000 SECTION

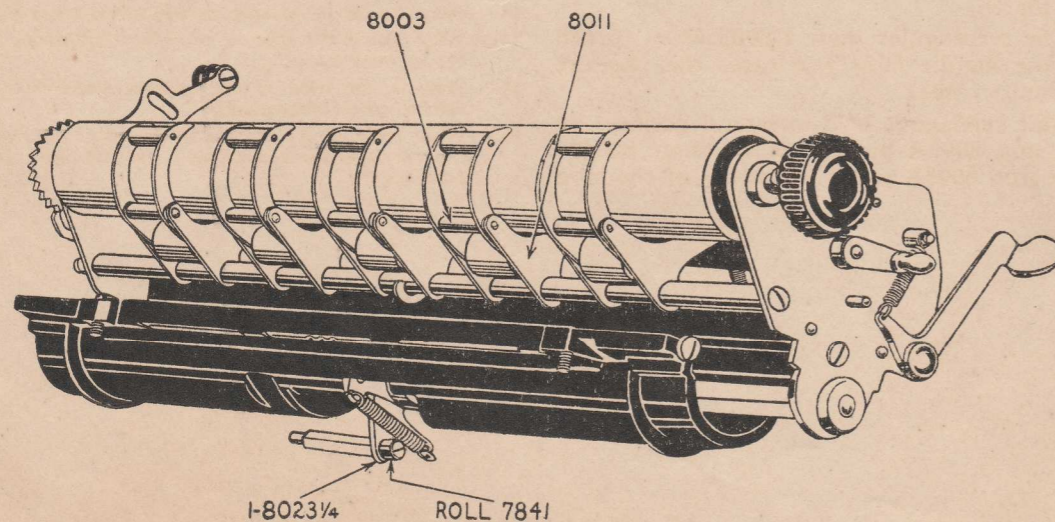
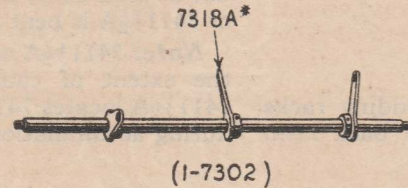
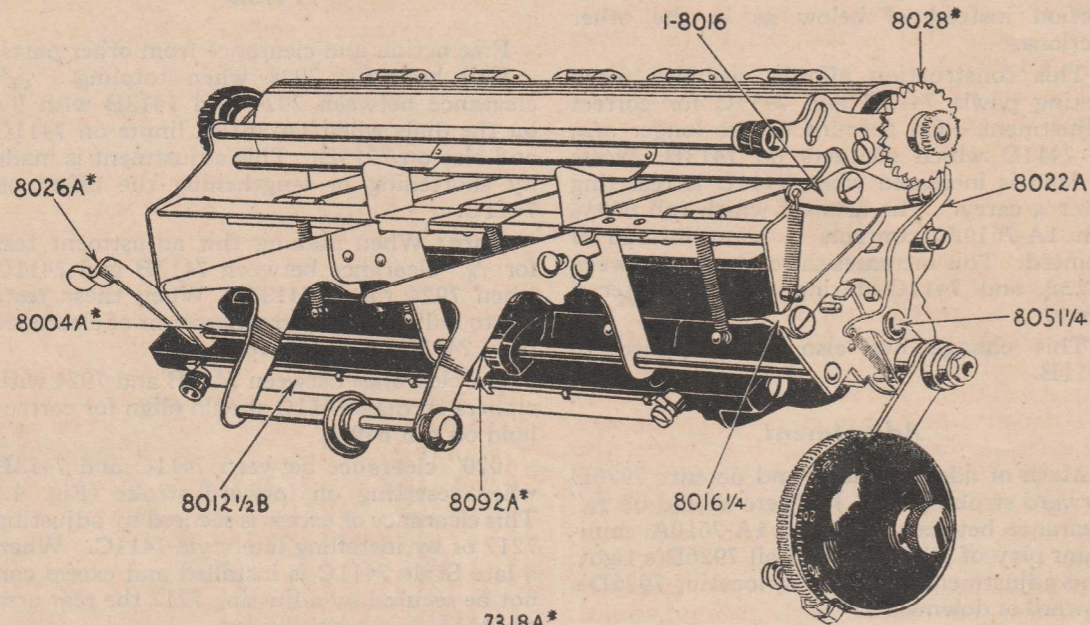

8000 Section

The Class 3 printing carriage is operated by the arm 7318A (on 1C-7302) which contacts with the roll 7841 carried by the part 1-8023¼ which oscillates in the stationary guide 1-8010 that is fastened to the lower casting 1-8067A.

The part 1-8023¼ has a square hole through which the square shaft 1-8007A slides when the carriage is moved from one column to another.

The square shaft 1-8007A carries the arm 1-8016½A on which the spacing pawl 8022A is pivoted. This spacing pawl swings on a center away from the ratchet wheel (on the 1-8007A) so that on the forward stroke the pawl 8022A is carried into the teeth of the ratchet and on the return stroke the platen is spaced and the pawl disengaged automatically. The detent 1-8016 insures even spacing and indicates a fixed printing line when the machine is in normal position.

Single, double and non-space is secured by the latch arm 8016¼A which has three positions. By shifting the latch 8016¼A into the different positions the movement of the spacing pawl 8022A on the forward stroke, is limited to engage one or two teeth or none at all.

The upper and lower pressure rolls pivot on the curved parts 8011⅛ which swing by their centers on the shaft 8003 carried by arms 8011. The arms are carried by the shaft, 8002, which is located between the side frames 1A-8017AR and BL, and spaced apart by the collars 8040 and 8040½. The springs 8085A hold the pressure rolls against the platen.

The rectangular shaft 1-8005 when turned by the handle 8024¼ releases the pressure roll units 1-8011.

This carriage is held in lateral position by the stop 8092A pinned to the shaft 8004A. The stop 8092A seats in notches of the stop

bar 8012½B. The arm 8026A (on 8004A) permits the shifting of the carriage by raising the stop 8092A out of the notches in the stop bar.

The stop 8092A is eccentric and when the stop bar is removed can be used as a friction stop for carriage.

Adjustment

The feed pawl 8022A must be perfectly free on the 8051¼ stud. At the end of the forward stroke the spacing pawl should have at least ⅛" lead over the ratchet 8028. The hold of the spacing pawl on the ratchet should provide sufficient lead for the detent 1-8016 to seat properly in the ratchet teeth.

With the machine in normal position there should be clearance between the top of the part 7318A (on 1-7302) and the roll 7841 (on 1-8023¼) to prevent binding of the carriage.

SELF-QUESTIONS

- 133—How is the Class 3 printing carriage operated by the mechanism of the machine?
- 134—Why does the part 1-8023¼ slide on a square shaft?
- 135—Describe the movement of the spacing pawl when the platen is turned?
- 136—What is the purpose of the detent 1-8016?
- 137—How does the latch arm 8016¼ determine single, double or non-space?
- 138—Why are the curved parts which carry the pressure rolls pivoted on the arms 8011 although the arms are movable on the shaft 8003?
- 139—How are the pressure rolls released from the platen?
- 140—Why should the spacing pawl 8022A move freely?
- 141—Why should the spacing pawl have clearance on the forward stroke?
- 142—How is the hold of the spacing pawl on the ratchet wheel determined?
- 143—What tests govern the part 7318 which operates the carriage mechanism and the roll 7841 (on 1-8023¼)?

INDEX

Introduction.....	1
Sections—7000 Section.....	3
Interlock.....	3
Adjustments.....	3
Sections—7200 Section.....	3
Keystems.....	3
Adjustments.....	3
Locking Bail.....	5
Adjustments.....	5
Key Restoring Unit.....	5
Adjustments.....	5
Locking Strips.....	5
Sub-total Key.....	5
Total Key.....	7
Non-add Mechanism.....	7
Sections—7300 Section.....	7
Adjustments.....	9
Sections—7500 Section.....	9
Adjustments.....	9
Ribbon Shift.....	9
Adjustments.....	11
Sections—7600 Section.....	11
Adjustments.....	11
Total Alignment.....	11
Test.....	11
Listing Alignment.....	11
Sector Lock Bail.....	13
Sections—7700 Section.....	13
Adjustments.....	13
7700 Section (7716B).....	13
Adjustments.....	15
7700 Section (1-7717B).....	15
Adjustments.....	15
Space Locks.....	17
Hammer Block Bail (7718B).....	19
S. K. S. Split Unit.....	19
Sections—7800 Section.....	19
Sequence of Timing Operation.....	20
Return Stroke.....	20
Sequence of Timing Tests.....	20
Speeds.....	20
Sections—7400 and 7900 Sections.....	23
Accumulator Adjustments.....	23
Tests.....	25
Class 3 Accumulator 2D-7900.....	27
Adjustments.....	27
Return Stroke.....	27
Section 2E-7900.....	29
Sections—8000 Section.....	31
Adjustments.....	31

